



**Pacific Northwest**  
NATIONAL LABORATORY

*Proudly Operated by **Battelle** Since 1965*

# Deployability of Small Modular Nuclear Reactors for Alberta Applications

Report Prepared for Alberta Innovates

**November 2016**

SM Short  
SD Unwin

B Olateju (AI)  
S Singh (AI)  
A Meisen (AI)

## DISCLAIMER NOTICE

This report was prepared under contract with the U.S. Department of Energy (DOE), as an account of work sponsored by Alberta Innovates (“AI”). Neither AI, Pacific Northwest National Laboratory (PNNL), DOE, the U.S. Government, nor any person acting on their behalf makes any warranty, express or implied, or assumes any legal liability or responsibility for the accuracy, completeness, or usefulness of any information, apparatus, product, or process disclosed, or represents that its use would not infringe privately owned rights. Reference herein to any specific commercial product, process, or service by trade name, trademark, manufacturer, or otherwise does not necessarily constitute or imply its endorsement, recommendation, or favoring by AI, PNNL, DOE, or the U.S. Government. The views and opinions of authors expressed herein do not necessarily state or reflect those of AI, PNNL, DOE or the U.S. Government.

# **Deployability of Small Modular Nuclear Reactors for Alberta Applications**

SM Short  
SD Unwin

B Olateju (AI)  
S Singh (AI)  
A Meisen (AI)

November 2016

Prepared for  
Alberta Innovates (AI)

Pacific Northwest National Laboratory  
Richland, Washington 99352



## Executive Summary

At present, the steam requirements of Alberta's heavy oil industry and the Province's electricity requirements are predominantly met by natural gas and coal, respectively. On November 22, 2015 the Government of Alberta announced its Climate Change Leadership Plan to 1) phase out all pollution created by burning coal and transition to more renewable energy and natural gas generation by 2030 and 2) limit greenhouse gas (GHG) emissions from oil sands operations. Small Modular Nuclear Reactors (SMNRs) could potentially play a role in providing competitively-priced, environmentally-acceptable, and dependable/reliable heat and power for the oil sands and electricity sectors, in order to meet the goals of the Climate Change Leadership Plan.

In support of this goal, Alberta Innovates (AI) contracted with Pacific Northwest National Laboratory (PNNL) to provide a realistic assessment of the current state of development, and the potential for further development, of SMNRs and their prospective application in Alberta for 1) producing GHG emissions-free steam and electricity for extracting oil from Alberta oil sands, 2) producing non-intermittent, reliable, GHG emissions-free electricity in Alberta's deregulated electricity market, and 3) providing reliable, GHG emissions-free district heating, desalinated water, and electricity for rural communities. The results of this assessment will be used to identify the most likely or viable SMNR designs that could be applied for the extraction of oil from Alberta oil sands by the year 2030. The application of SMNRs to the other two applications may be addressed in subsequent work.

Small nuclear reactors, according to the classification adopted by the International Atomic Energy Agency (IAEA), are nuclear reactors with an equivalent electric power generation design capacity of less than about 300 MW<sub>e</sub>. The term "modular" in the context of SMNRs refers to the ability to fabricate major components of the nuclear steam supply system (NSSS) in a factory environment and to deliver and assemble these components at a site in modules. This method of modular construction contrasts with that historically used for the construction of large baseload nuclear power plants (NPPs) wherein much of the plant requires on-site, custom-built construction. The historical philosophy of constructing large baseload plants is to reduce the unit cost of electricity (i.e., \$/kW<sub>e</sub>) by taking advantage of economies-of-scale expected from larger capacity plants. However, the potential economic benefits of economies-of-scale for large nuclear power plants were often offset and even overwhelmed by cost increases due to extended construction periods resulting from the increased size and complexity of the NSSS and associated safety systems to meet safety and regulatory requirements. The expected economic benefit of SMNRs is significantly reduced construction schedules and associated reduction in financial risk from their smaller size and simpler design.

Dozens of SMNR designs are currently under development in many countries. The design concepts span a range of nuclear reactor technologies, and are at various phases of development ranging from basic concept description, to detailed design, to under construction. Many of these designs were reviewed at a high level and included in this assessment if they were judged to be under active development for deployment as SMNRs and to be deployable by about the 2030 time frame. Twenty-six reactor designs were included in the assessment representing the following general reactor types: (1) integral pressurized water reactors (iPWRs), (2) heavy-water cooled and moderated reactors (HWRs), (3) high-temperature gas-cooled reactors (HGTRs), (4) molten salt reactors (MSRs), (5) sodium fast reactors (SFRs), (6) gas-cooled fast reactors (GFRs), and (7) heavy liquid metal-cooled (HLMC) fast reactors. It should be noted

however that this SMNR technology review was not an exhaustive attempt to identify and review all SMNR designs that are currently being developed. Such an effort was beyond the scope of this assessment. Rather, the intent of this assessment was to include the most prominent SMNR designs currently under active development, and to include a select set of SMNR designs that represented a broad base of technology and deployment options.

Generally, as with new large baseload NPPs, most of the SMNRs are being designed for operating lives of up to 60 years, and even longer in some cases. However, when the SMNR has been permanently shutdown and is to be decommissioned, each SMNR type poses different and unique challenges. There is a significant amount of experience with decommissioning iPWR-type reactors, including long-term storage of used nuclear fuel and final disposal of radioactively-contaminated materials. This is because iPWRs use similar fuel and have similar reactor components/materials as used in NPPs in common use today, of which many have been fully decommissioned and dismantled. There is significantly less decommissioning and dismantlement experience with HWRs and HTGRs, which can potentially contain significant quantities of the isotope Carbon-14, which requires specialized treatment to ensure long-term isolation after final disposal. Finally, there is little or no decommissioning and dismantlement experience with the other reactor types (i.e., MSRs, SFRs, GFRs, and HLMC fast reactors). These reactor types use non-standard coolant materials that, in some cases, are highly pyrophoric or toxic and so require specialized treatment for final disposal. For all of the SMNR types, however, final disposition of the used nuclear fuel produced during the operating life of the plant poses regulatory and political challenges that have not been fully resolved by any country to-date. On the other hand, long-term interim storage of used nuclear fuel has been demonstrated and is expected to be safe for 100+ years.

Each of the SMNR designs were evaluated using Decision Analysis techniques with an end goal to develop an overall ranking of each concept relative to a pre-defined set of criteria. These techniques were chosen because they make explicit the rationale by which the reactor designs were evaluated, promote clarity in the thought process for ranking the designs, and aided the specification of the information that needed to be developed for each design in order to perform the evaluation. PNNL and AI worked together to jointly develop the Decision Analysis tool or “SMNR Ranking Model” used to evaluate each of the reactor designs in a structured format using the same technology-neutral criteria for each reactor design.

A two-step analysis method was developed to provide 1) a ranking of each SMNR concept based on full compliance with the evaluation criteria and 2) a ranking of each SMNR concept based on full and partial compliance with the evaluation criteria. The “Full Compliance Ranking Model” was developed to provide a simple assessment of whether or not each reactor concept meets the high-level objectives or criteria important to AI. The “Full and Partial Compliance Ranking Model” was developed to provide a more detailed assessment or measure of the degree to which each of the criteria are achieved. A set of 13 criteria were defined as being relevant to the assessment of SMNR designs in Alberta. These criteria primarily relate to the capability of the various SMNR designs to meet the goals of the Climate Change Leadership Plan discussed above, and include other performance metrics considered potentially important to various stakeholders. For the “Full Compliance Ranking Model,” the criteria are as follows:

- Commercial Deployment – Is the reactor concept commercially deployable by the year 2030?

- Steam Quality – Is the quality of the steam directly produced by the reactor sufficient to support SAGD for oil recovery from Canada’s oil sands (i.e., steam pressure and temperature is  $\geq 9$  MPa and  $315^{\circ}\text{C}$ , respectively)?
- Technology Readiness Level (TRL) – Is the TRL or development state of the reactor concept  $\geq 5$  (i.e., component validation has been performed in the relevant reactor operating environment)?
- Steam Production – Is the steam production capacity of the reactor  $\geq 655,200$  kg/hr (i.e., the steam production rate required for a typical SAGD operation)?
- Power Rating – Is the power rating (electricity production capacity) of the reactor  $\geq 11$  MW<sub>e</sub> and  $\leq 18$  MW<sub>e</sub> (i.e., the amount of electricity required for a typical SAGD operation)?
- Safety – 1) Does the reactor design incorporate advanced inherent/passive safety features to prevent/mitigate severe accidents? 2) Does the reactor not use a coolant that is chemically-reactive with air or water?
- Spent Fuel Management – 1) Does the used nuclear fuel require on-site treatment after discharge? 2) Does the reactor vendor disposition the used nuclear fuel?
- Low-level Radioactive Waste/Intermediate-level Radioactive Waste (LLW/ILW) Management – Does the reactor plant concept generate little or no LLW/ILW during plant operations?
- Decommissioning – Has decommissioning of the reactor type been demonstrated?
- Alberta Adaptability – Does the reactor plant concept require on-site trained nuclear operators?
- Levelized Cost of Electricity (LCOE) – Is the estimated LCOE (based on U.S. 2015 \$) for the reactor concept competitive with the LCOE for combined-cycle natural gas plants?

The answer to each of the above questions is either “YES” or “NO.” For the purposes of the quantitative ranking model, an answer of “YES” is assigned a numerical scoring value of “1” while an answer of “NO” is assigned a numerical scoring value of “0.”

For the “Full and Partial Compliance Ranking Model”, the 13 criteria are the same as described above. However, rather than just a binary score of “YES” or “NO,” a score from 1 to 10 is assigned to reflect partial compliance with the criteria. The criteria for each of the potential scores are provided in Table ES-1 for each of the 13 criteria.

Finally, each of the 13 criteria was assigned a weight from 1 and 10 by AI to reflect the relative importance of each of the criteria to the reactor design down-select decision. This report assesses each of the 26 reactor designs and evaluates them against each of the 13 criteria using the scoring methods described. To support the evaluation, an Excel<sup>®</sup> database was developed to contain the design details, design development schedule and status, and other characteristics of each reactor design necessary for this evaluation. The database was developed using only publicly-available information readily accessible to PNNL. No reactor vendors were contacted to provide information to support this evaluation.

Figure ES-1 provides the ranking results for both models. Generally, reactor concepts based on HTGR technology ranked the highest of the reactor types, which is not unexpected since HTGRs operate at temperatures and pressures that readily support the generation of steam having sufficient quality for oil sands Steam Assisted Gravity Drainage (SAGD) operations. The reactor design having the highest aggregate score was the StarCore HTGR [Canada]. While the StarCore SMNR concept scored very low on technology readiness level (TRL) and commercial deployment schedule, it scored very high on spent fuel management, adaptability to Alberta conditions, and plant decommissioning. This is because, according to StarCore 1) it provides all spent fuel management so that associated operator skills (i.e., refueling) and used fuel storage capability does not need to exist at the reactor site, 2) it provides remote operation and monitoring of the plant so that very few highly-skilled and trained nuclear operators and security staff are required on-site, and 3) as the owner-operator of the plant, it provides for plant decommissioning, including removal of the entire reactor, and associated used fuel, from the plant site every five years.

While many implementation details of the StarCore concept remain to be developed, or made publicly available, PNNL believes the following aspects of this concept pose difficult and likely unrealistic licensing and regulatory challenges for implementation by 2030: 1) remote monitoring and operation of the reactor at a centralized StarCore-operated facility, which poses a difficult licensing challenge due to cyber-security concerns that will have to be overcome, 2) licensing the RPV or reactor core module as a transportation container/package for used nuclear fuel, which will require the RPV/container to meet the licensing (including testing) requirements for used fuel transportation casks, 3) licensing the RPV or reactor core module as a transportation container/package for new nuclear fuel will require, likely via testing, that the RPV/internal components/new fuel meet stringent quality assurance requirements, following transportation to and installation at the reactor site and prior to operation, 4) away-from-reactor centralized used fuel storage facility<sup>1</sup> that will be available to receive and interim store the RPV/used fuel, and which will require its own license, and 5) making the reactor site completely accessible to the public with no overt security fences or guards, while still meeting strict physical security requirements, including robust physical defenses and a plant security force.

Also highly ranked was the HTR50S HTGR reactor by the Japan Atomic Energy Agency (JAEA). This reactor concept scored very high on TRL because its design is based on the same design as has been deployed in an engineering scale test reactor in Japan since 1998. JAEA claims that no further technology development is needed and so the reactor concept is available now for deployment, although further design development is needed to support commercial deployment. JAEA however does not offer the same used fuel management, owner-operator, and decommissioning services as StarCore, and so scores lower on these criteria.

One other reactor design that ranked high was the 4S SFR by Toshiba. As with HTGRs, reactor concepts based on SFR technology score high on generating steam having sufficient quality for oil sands SAGD operation. The 4S also scored very high on TRL because of completed and on-going testing in sodium-cooled experimental reactors. The 4S reactor also ranked high based on its detailed design development being well advanced, and small operating crew because of a long refueling cycle and sealed reactor vessel that essentially only requires active monitoring.

---

<sup>1</sup> Currently, used nuclear fuel from Canada's nuclear power reactors are maintained in interim storage facilities located at the nuclear reactor sites.



In general, iPWRs HWRs, and HLMC reactors ranked lower than the other reactor types because they do not directly generate steam having sufficient quality suitable for use in many high temperature/pressure process heat applications generally and for SAGD operation specifically (i.e., the temperature and pressure of the steam are less than 315°C and 9 MPa, respectively). It is noted however that steam having sufficient quality to support SAGD operation can be generated with incorporation of an energy upgrade technology into the SMNR process. There are a number of options for upgrading the steam produced with these SMNRs. For example, one potential option is to incorporate a steam compressor into the balance-of-plant process to increase the temperature and pressure of the steam directly produced from the iPWR reactor. Another option is to use the electricity produced by the SMNR to power an electric boiler to produce SAGD quality steam. However, these options, or additional process steps, increase the cost of these SMNR technologies for the SAGD application. Furthermore, both of these options require further design and technology development to make them commercially available to support SAGD operation.

Several sensitivity cases were also evaluated to assess the relative importance of the weighting factors used in this analysis. In all cases, the HTR50S HTGR and 4S FSR ranked in the top three. The StarCore HTGR also generally ranked in the top three, although it dropped out of the top three ranking in one sensitivity case in which the criteria not directly related to meeting Alberta's Climate Change Leadership Plan goals were disregarded. Also, all of the HTGR designs evaluated in this report ranked high in meeting Alberta's climate change goal of limiting GHG emissions from oil sands operations in the baseline assessment and in all of the sensitivity cases.

Finally, the report provides recommendations on next steps to consider before making a final down-select decision.

Table ES-1. Scoring Criteria

Score	Commercial Deployment	Steam Quality	TRL	Steam Production	Power Rating	Safety – Inherent/Passive Safety Features	Safety – Chemically-reactive Coolant	Spent Fuel Management – On-site Treatment
1	Concept Description	SAGD quality steam produced with addition of energy upgrade technology	1-2	Direct Produced Steam Quality < 1 MPa	Single Module > 100 MW <sub>e</sub>	< 36 hours grace period	Coolant that is chemically-reactive with air/water is used	Continuous on-line refueling
2	Testing to Support Conceptual Design			Direct Produced Steam Quality ≥ 1 MPa, < 3 MPa		36+ hours grace period		≤ 18 month discharge cycles
3	Conceptual Design Completed							
4	Basic Design in Process		2-3	Direct Produced Steam Quality ≥ 3 MPa, < 5 MPa	Single Module > 50 MW <sub>e</sub> and ≤ 100 MW <sub>e</sub>	72+ hours grace period		> 18-36 month discharge cycles
5	Basic Design Completed							
6	Detailed Design in Process (testing)		3-4	Direct Produced Steam Quality ≥ 5 MPa, < 7 MPa	Single Module > 30 MW <sub>e</sub> and ≤ 50 MW <sub>e</sub>	7+ days grace period		> 3-5 year discharge cycles
7	Detailed Design Completed							
8	Prototype under Construction		4-5	Direct Produced Steam Quality ≥ 7 MPa, < 9 MPa	Single Module > 18 MW <sub>e</sub> and ≤ 30 MW <sub>e</sub>	Unlimited grace period		> 5 year discharge cycles
9	Prototype in Operation							> 25 year discharge cycles
10	Licensed in US, Canada, or Europe	SAGD quality steam produced directly	≥ 5	Direct Produced Steam Quality ≥ 9 MPa	Single Module > 11 MW <sub>e</sub> and ≤ 18 MW <sub>e</sub>	Natural circulation; unlimited grace period	Coolant that is chemically-reactive with air/water is not used	Spent fuel removed from site

Table ES-1. Scoring Criteria (Continued)

Score	Spent Fuel Management – Vendor Disposition	LLW/ILW Management	Decommissioning	Alberta Adaptability	LCOE (based on U.S. 2015 \$)
1	Burnup < 10 gigawatt-days (GWd)/ton, thereby maximizing volume	LLW/ILW generated during operations potentially contain significant activation products having >> 50 yr half-life	LLW/ILW with half-life ( $T_{1/2}$ ) > 100 years and coolant/moderator requires specialized treatment/stabilization	Senior Reactor Operator (SRO), nuclear plant, refueling, and fuel processing operators required	> Not competitive (> 130 \$/MW-hr)
2	Burnup $\geq$ 10 GWd/ton			SRO, nuclear plant continuous refueling operators	> 120 \$/MW-hr and $\leq$ 130 \$/MW-hr
3	Burnup $\geq$ 30 GWd/ton				Competitive with conventional gas turbine (> 110 \$/MW-hr and $\leq$ 120 \$/MW-hr)
4	Burnup $\geq$ 60 GWd/ton		LLW/ILW with $T_{1/2}$ > 100 years and coolant/moderator requires specialized treatment/stabilization	SRO, nuclear plant, refueling, and specialized coolant handling operators	Competitive with advanced large nuclear (> 100 \$/MW-hr and $\leq$ 110 \$/MW-hr)
5		LLW/ILW generated during operations mostly fission/activation products having < 50 year half-life; use of UO <sub>2</sub> fuel			Competitive with NuScale SMNR (> 90 \$/MW-hr and $\leq$ 100 \$/MW-hr)
6	Burnup $\geq$ 100 GWd/ton	LLW/ILW generated during operations mostly fission/activation products having < 50 year half-life; use of higher integrity metallic fuel		SRO, nuclear plant and periodic (2-year) refueling operators (vendor supported)	Competitive with combined cycle natural gas with carbon sequestration (CCS) (> 80 \$/MW-hr and $\leq$ 90 \$/MW-hr)
7			LLW/ILW with $T_{1/2}$ < 100 years and coolant/moderator does not require specialized treatment/stabilization		> 70 \$/MW-hr and $\leq$ 80 \$/MW-hr
8	Very high burnup (maximizes use of fuel, thereby minimizing volume)	Low volume of LLW/ILW generated during operations because of high integrity, fail-safe fuel; mostly fission/activation products having < 50 year half-life		SRO, few nuclear plant operators, and no refueling operators (vendor provided for very long refueling cycles)	Competitive with wind/hydro (> 60 \$/MW-hr and $\leq$ 70 \$/MW-hr)
9					Competitive with combined cycle natural gas (> 50 \$/MW-hr and $\leq$ 60 \$/MW-hr)
10	Spent fuel removed from site	Sealed reactor vessel so very little LLW/ILW generated during operations	LLW/ILW with $T_{1/2}$ < 100 years and coolant/moderator does not require specialized treatment/stabilization, and high integrity fuel or reactor removed from site	No nuclear trained operators required (remote operation)	Competitive with geothermal ( $\leq$ 50 \$/MW-hr)

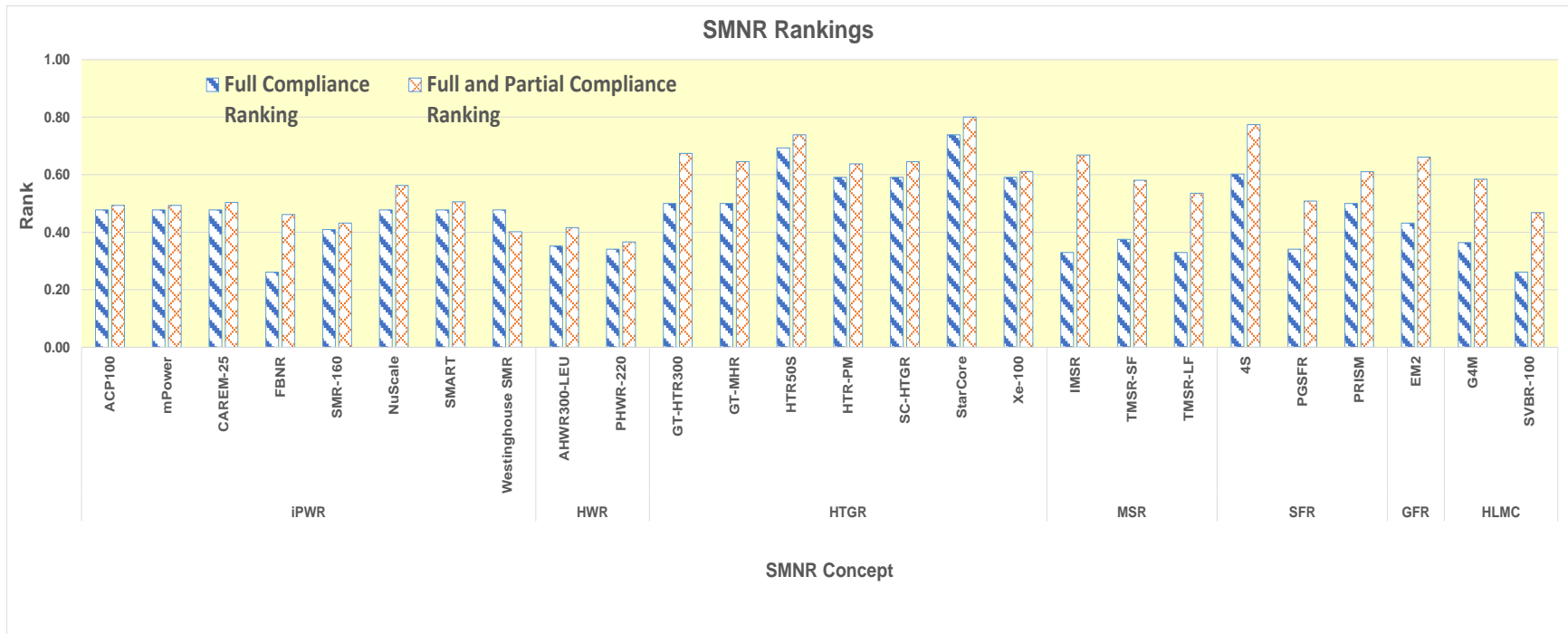

Figure ES-1. Comparison of SMNR Rankings

## Acknowledgments

The PNNL authors are grateful for the assistance provided by AI to the development of the SMNR ranking models used in this report and for the extensive review of this report provided by AI staff. The authors are also grateful for the PNNL peer reviewers Dr. Ron Omberg (sodium fast reactors), Pete Lowry (iPWRs and high-temperature gas reactors), and Steven Ross (all other aspects of the report) for their review and comments on this report.



## Acronyms and Abbreviations

AHWR	advanced heavy water reactor
ASP	Accident Sequence Precursor
AC	alternating current
AI	Alberta Innovates
Bi	bismuth
bpd	barrels per day
BWR	boiling water reactor
CANDU	CANadian Deuterium Uranium
CRD	control rod drive
CRDM	control rod drive mechanism
DC	direct current
DOE	U.S. Department of Energy
D <sub>2</sub> O	deuterium oxide
EFW	emergency feedwater
EPZ	Emergency Planning Zone
FOAK	first-of-a-kind
FSAR	Final Safety Analysis Report
GFR	gas-cooled fast reactor
GHG	greenhouse gases
HLMC	heavy liquid metal-cooled fast reactor
HTGR	high-temperature gas-cooled reactor
HWR	heavy-water reactor
IAEA	International Atomic Energy Agency
IHTS	intermediate heat transport system
IHX	intermediate heat exchanger
ILW	intermediate-level radioactive waste
INES	International Nuclear and Radiological Event Scale
INL	Idaho National Laboratory
iPWR	integral pressurized-water reactor
JAEA	Japan Atomic Energy Agency
KW	kilowatt
LBE	lead-bismuth eutectic
LCOE	levelized cost of energy
LER	Licensee Event Report
LEU	low enriched uranium

LLW	low-level radioactive waste
LOCA	loss-of-coolant accident
LWR	light-water reactor
m	meter
MCFR	molten chloride fast reactor
MFW	main feedwater
MOX	mixed uranium-plutonium oxide
MIT	Massachusetts Institute of Technology
MPa	megapascal
MSFR	molten salt fast reactor
MSR	molten salt reactor
MSRE	Molten-Salt Reactor Experiment
MT	metric ton
MW	megawatt
MW <sub>e</sub>	megawatt electric
MWhr	megawatt-hour
MW <sub>th</sub>	megawatt thermal
NEI	Nuclear Energy Institute
NGNP	Next Generation Nuclear Plant
NHSS	nuclear heat supply system
NOAK	n <sup>th</sup> -of-a-kind
NPP	nuclear power plant
NRC	Nuclear Regulatory Commission
ORNL	Oak Ridge National Laboratory
Pb	lead
PCS	primary cooling system
PHTS	primary heat transport system
PHWR	pressurized heavy water reactor
PNNL	Pacific Northwest National Laboratory
PORV	power-operated relief valve
PSAR	Preliminary Safety Analysis Report
PTAC	Petroleum Technology Alliance Canada
PWR	pressurized-water reactor
RCS	reactor coolant system
RPV	reactor pressure vessel
SAGD	Steam-Assisted Gravity Drainage
SBO	station blackout
SCWR	super-critical water reactor



SFR	sodium fast reactor
SMNR	Small Modular Nuclear Reactor
SOW	statement of work
TRISO	tristructural-isotropic
TRL	technology readiness level
UO <sub>2</sub>	uranium dioxide
yr	year



# Contents

Executive Summary .....	iii
Acknowledgments.....	xi
Acronyms and Abbreviations .....	xiii
1.0 Introduction .....	1.1
1.1 Background .....	1.1
1.2 Study Objectives .....	1.2
1.3 Key Intelligence Outcomes and Study Purpose .....	1.3
2.0 Background on SMNRs.....	2.1
2.1 Current Deployed Nuclear Reactor Fleet .....	2.1
2.2 Nuclear Power Cost Drivers.....	2.3
2.3 Common Features of SMNRs that Increase Safety and Reduce Cost.....	2.4
2.4 SMNR Decommissioning .....	2.6
3.0 Integral Pressurized-Water Reactors .....	3.1
3.1 Small iPWR Concepts.....	3.2
3.2 Operational Experience with iPWRs.....	3.12
4.0 Small Heavy Water Reactors (HWRs) .....	4.1
4.1 Small HWR Concepts .....	4.2
4.2 Operational Experience with Small HWRs.....	4.5
5.0 Small High-Temperature Gas-Cooled Reactors .....	5.1
5.1 Small HTGR Concepts.....	5.3
5.2 Operational Experience with Small HTGRs .....	5.13
6.0 Molten Salt Reactors .....	6.1
6.1 Small MSR Concepts .....	6.2
6.2 Operational Experience with MSRs.....	6.5
7.0 Fast Reactors.....	7.1
7.1 Small HLMC Fast Reactor Concepts .....	7.2
7.2 Small Gas-Cooled Fast Reactors Concepts .....	7.7
7.3 Small Molten Salt Fast Reactors Concepts .....	7.7
7.4 Small Sodium Fast Reactor Concepts .....	7.8
7.5 Operational Experience with Sodium Fast Reactors .....	7.14
8.0 SMNR Ranking Model.....	8.1
8.1 Ranking by Full Compliance with Individual Criteria .....	8.1
8.2 Ranking by Full and Partial Compliance with Individual Criteria.....	8.4
8.3 Ranking Model Results .....	8.7
8.4 Sensitivity Cases .....	8.12
9.0 Conclusions and Recommendations .....	9.1

10.0 References ..... 10.1  
Appendix A Comprehensive WANT Statement ..... A.1  
Appendix B Assigned Scores for Each Ranking Model ..... B.1

# Figures

Figure ES-1. Comparison of SMNR Rankings .....	x
Figure 3-1. Conceptual Drawing of ACP-100 Reactor .....	3.3
Figure 3-2. Conceptual Drawing of the mPower™ Reactor Module and Two-unit Plant .....	3.4
Figure 3-3. Conceptual Drawing of the CAREM-25 Reactor .....	3.5
Figure 3-4. Conceptual Drawing of the FBNR .....	3.6
Figure 3-5. Conceptual Drawing of SMR-160 Reactor Module and Plant .....	3.8
Figure 3-6. Conceptual Drawing of NuScale Reactor Module and Plant .....	3.9
Figure 3-7. Conceptual Drawing of SMART Reactor .....	3.10
Figure 3-8. Conceptual Drawing of the Westinghouse SMR Reactor Module and Plant .....	3.12
Figure 4-1. Conceptual Drawing of the AHWR300-LEU Reactor .....	4.3
Figure 4-2. Conceptual Drawing of the PHWR-220 Reactor .....	4.4
Figure 5-1. Schematic of a Typical TRISO Fuel Pebble .....	5.2
Figure 5-2. Schematic of a Typical Prismatic-block Fuel Assembly .....	5.2
Figure 5.1-1. Conceptual Drawing of the GT-HTR300 Reactor System and Hydrogen Production Plant .....	5.4
Figure 5.1-2. Heat/Energy Balance for the GT-HTR300 Plant Producing Electricity .....	5.5
Figure 5.1-3. Conceptual Drawing of the GT-MHR Plant Configuration .....	5.6
Figure 5.1-4. Conceptual Drawing of HTR50S Reactor System and Plant Configuration .....	5.7
Figure 5.1-5. Heat/Energy Balance for the HTR50S Plant .....	5.8
Figure 5.1-6. Conceptual Drawing of HTR-PM Reactor System and 2-Unit Plant Configuration .....	5.9
Figure 5.1-7. Conceptual Drawing of SC-HTGR Reactor System and Silo .....	5.10
Figure 5.1-8. Conceptual Drawing of Xe-100 Reactor System and 4-Unit Plant Configuration .....	5.13
Figure 6.1-1. Conceptual Drawing of the IMSR System and Plant Configuration .....	6.3
Figure 6.1-2. Conceptual Drawing of the TMSR-SF1 Reactor .....	6.4
Figure 7.1-1. Conceptual Drawing of G4M Power Plant .....	7.4
Figure 7.1-2. Conceptual Drawing of PEACER-300 .....	7.5
Figure 7.1-3. Conceptual Drawing of the SVBR-100 Reactor Concept .....	7.6
Figure 7.2-1. Conceptual Drawing of EM <sup>2</sup> Reactor Containment and Plant Configuration .....	7.8
Figure 7.4-1. Conceptual Drawing of the 4S Reactor and Plant Configuration .....	7.9
Figure 7.4-2. Conceptual Drawing of the PGSFR Plant Configuration .....	7.11
Figure 7.4-3. Mass/Heat Balance of the PGFSR .....	7.11
Figure 7.4-4. Conceptual Drawing of the PRISM Plant Configuration .....	7.13
Figure 7.4-5. Conceptual Drawing of the PHTS .....	7.13
Figure 8.3-1. Comparison of SMNR Rankings .....	8.11

# Tables

Table ES-1. Scoring Criteria.....	viii
Table 8.2-1. Scoring Criteria.....	8.5
Table 8.3-1. Ranking Model Results .....	8.10
Table 8.4-1. Sensitivity Case 1 Ranking Model Results.....	8.13
Table 8.4-2. Sensitivity Case 2 Ranking Model Results.....	8.14
Table 8.4-3. Sensitivity Case 3 Ranking Model Results.....	8.15
Table B-1. Scores for the Full Compliance Ranking Model.....	B.2
Table B-2. Scores for the Full and Partial Compliance Ranking Model.....	B.3

# 1.0 Introduction

## 1.1 Background

On November 22, 2015 the Government of Alberta announced its Climate Change Leadership Plan, which included the following statements:

- *“The government will legislate an overall oil sands emissions limit. We will grow our economy by applying technology to reduce our carbon output per barrel, which is what this limit will promote.*
- *An overall oil sands emission limit of 100 megatonnes will be set, with provisions for new upgrading and co-generation.*
- *Alberta will phase out all pollution created by burning coal and transition to more renewable energy and natural gas generation by 2030.”*

At present, the steam requirements of the heavy oil industry and the Province’s electricity requirements are predominantly met by natural gas and coal, respectively. Small Modular Nuclear Reactors (SMNRs) could potentially play a role in providing competitively-priced, environmentally-acceptable, and dependable/reliable heat and power for the oil sands and electricity sectors, in order to meet the above-stated aspects of the Climate Change Leadership Plan.

SMNRs have the following potential advantages relative to current generation power sources, including, in some cases, large nuclear power plants:

- Near zero emissions of greenhouse gases (GHGs) and other potentially deleterious substances during operation;
- Passive and inherent safety features compared to existing NPPs that substantially reduce the risk of severe accidents<sup>2</sup>;
- Enhanced nonproliferation benefits compared to existing NPPs that reduce the risk of diversion or theft of nuclear materials;
- Economics and quality afforded by factory production of plant components compared to the on-site fabrication and construction used at existing NPPs; and
- More flexibility relative to large nuclear power plants in terms of financing (lower initial capital investment and therefore lower risk), scalability (incremental capacity additions are smaller and

---

<sup>2</sup> Passive safety features are plant components that will act to safely shutdown the nuclear reactor during an off-normal operational-upset event without the use of operator actions or the use of actively-operated systems. An example is the use of natural circulation of reactor coolant to passively remove decay heat in the reactor core in the event there is a loss of electric power to the plant that prevents the use of pumps, motor-operated valves, etc., that would generally be used during normal plant operation to provide forced circulation of coolant to remove the reactor decay heat. In contrast, inherent safety features refer to the natural nuclear response characteristics of the fuel/coolant that act to slowdown the nuclear chain reaction when a certain characteristic of the material changes. For example, all reactors licensed by the NRC in the U.S. must have a negative fuel temperature coefficient of reactivity meaning that as the temperature of the fuel increases (such as due to a loss of decay heat removal capability), the reactivity or power level of the reactor will decrease and return the reactor to its original state.

more adaptable to changing power requirements and needs), and plant siting (can be installed at locations unable to accommodate traditional larger reactors).

Potential disadvantages of SMNRs relative to current generation power sources, including, in some cases, large nuclear power plants:

- Lack of economies-of-scale for both construction and operating costs that are available with larger nuclear power plants (although the simpler designs of SMNRs may be able to offset this disadvantage to some extent);
- Lack of an available supply chain for specialized reactor components and for nuclear fuel types that are significantly different than the light-water reactor fuel currently used predominantly around the world;
- As with nuclear power plants generally, SMNRs generate used nuclear fuel that remains radioactive for thousands of years thereby requiring specialized treatment and disposition; and
- As with nuclear power plants generally, SMNRs generate radiation and radioactive materials that can be inadvertently released into the environment either during normal operations or as the result of a severe accident (although, as discussed above, the risk of severe accidents is substantially reduced in most SMNRs designs).

SMNR technology has great potential significance to Alberta, especially if SMNRs can be demonstrated to be viable under Alberta conditions and applicable to the Province's oil sands and electricity generating industries. These industries need to know about major developments that may affect their business and choice of energy sources. An understanding of the commercial potential of SMNRs is therefore very important to these industries.

With this background, Alberta Innovates (AI) contracted with PNNL to evaluate advances in SMNR technology and their potential for application in Alberta for reducing GHG emissions through power generation and multi-purpose steam, electricity, and/or heat generation.

## **1.2 Study Objectives**

The objective of this study is a high-level assessment of the current state of development, and potential for further development of SMNRs, and their prospective application in Alberta for:

- Oil Sands Sector: multi-purpose process steam/electricity/district heat generation for Alberta's oil sands Steam-Assisted Gravity Drain (SAGD) operations to fulfill future growth and to reduce GHG emissions;
- Power Sector: power (electricity) generation to fulfill future growth and to provide GHG emissions-free, reliable, non-intermittent electricity supply, in accordance with the Climate Change Leadership Plan; and



- Rural Communities: multi-purpose district heat/desalinated water production/electricity generation for rural communities to fulfill future growth and to replace aging plants and to reduce greenhouse gas emissions.

The results of this assessment will be used to identify the most likely or viable SMNR concepts that could be applied for the extraction of oil from Alberta oil sands by the year 2030. The application of SMNRs to the other two applications may be addressed in subsequent work.

### 1.3 Key Intelligence Outcomes and Study Purpose

The purpose of this study is to provide technology intelligence to AI in the area of SMNR technologies and their deployability for Alberta applications. The Key Intelligence Outcomes are:

- Identification of the SMNR existing/emerging technologies that satisfy the operational requirements of SAGD, electricity markets, or remote communities' applications;
- Identification and assessment of the technical and non-technical factors that pose challenges to SMNR technologies and how they can be overcome; and
- Identification of potential innovative solutions to overcome these challenges.

The technical and non-technical factors to be considered in this study are identified in the "Comprehensive WANT Statement" provided in Appendix A.

In accordance with the "Comprehensive WANT Statement," this report will not duplicate previous work that has been conducted by Petroleum Technology Alliance Canada (PTAC), where the use of nuclear power plants (NPPs) such as well as high temperature gas cooled SMNRs for SAGD and surface mining applications in Alberta's oil sands industry were investigated. The PTAC studies, and other reports produced by Massachusetts Institute of Technology (MIT) and University of Texas at Austin, focus on oil sands applications and are representative of the state of the technology as of 2011 in the best case. Below is a listing of these studies and reports:

Idaho National Laboratory (INL) and Petroleum Technology Alliance Canada (PTAC), October 2011, "Integration of High Temperature Gas-cooled Reactor Technology with Oil Sands Processes," INL/EXT-11-23239, Next Generation Nuclear Plant Project, Idaho Falls, Idaho.

Massachusetts Institute of Technology (MIT), 2005, "Nuclear Technology & Canadian Oil Sands: Integration of Nuclear Power with In-Situ Oil Extraction," Cambridge, MA.

MPR Associates Inc., March 2009, "Evaluation of High Temperature Reactors for Potential Application to Thermal In-Situ Recovery of Oil Sands," Report MPR-3254 prepared for Petroleum Technology Alliance Canada, Calgary, Alberta, Canada.

SNC•Lavalin Nuclear, Inc., May 2008, "Nuclear Energy Options Evaluation Report," Document Number 017759-0000-45RA-0001, Oil Sands Phase 1 Energy Options Feasibility Study.

University of Texas at Austin, August 2010, “A Real Options Analysis and Comparative Cost Assessment of Nuclear and Natural Gas Applications in the Athabasca Oil Sands,” Thesis by Julia Blum Harvey, B.A., Austin, Texas.

Technology intelligence studies which investigate SMNR deployment in Alberta’s electricity market and remote communities, along with oil sands (SAGD) applications, are relatively scarce. Moreover, some notable developments in the SMNR technology landscape are likely to have occurred since 2011. This report focuses on the changes to the SMNR technology landscape since 2011. Reports specifically included in the assessment are:

Hatch Ltd., June 2016, “SMR Deployment Feasibility Study – Feasibility of the Potential Deployment of Small Modular Reactors (SMRs) in Ontario,” Report No. H350381-00000-162-066-0001, Rev. 0, prepared for the Ontario Ministry of Energy  
([http://ontarioenergyreport.ca/pdfs/MOE%20-%20Feasibility%20Study\\_SMRs%20-%20June%202016.pdf](http://ontarioenergyreport.ca/pdfs/MOE%20-%20Feasibility%20Study_SMRs%20-%20June%202016.pdf)).

IAEA, September 2014, "Advances in Small Modular Reactor Technology Developments, A Supplement to: IAEA Advanced Reactors Information System (ARIS)," Vienna, Austria  
([https://www.iaea.org/NuclearPower/Downloadable/SMR/files/IAEA\\_SMR\\_Booklet\\_2014.pdf](https://www.iaea.org/NuclearPower/Downloadable/SMR/files/IAEA_SMR_Booklet_2014.pdf)).

## 2.0 Background on SMNRs

Small nuclear reactors, according to the classification adopted by the IAEA, are reactors with an equivalent electric power generation design capacity of less than about 300 MW<sub>e</sub>. This is significantly less than the typical current generation base load plants that can have design capacities of up to 1000 MW<sub>e</sub> or greater.

The term “modular” in the context of SMNRs refers to the ability to fabricate major components of the nuclear steam supply system in a factory environment and ship to the point of use by truck, rail, or ship/barge. SMNRs are envisioned to require limited on-site preparation and substantially reduce the lengthy construction times that are typical of larger nuclear power plants. SMNRs provide simplicity of design, enhanced safety features, the economics and quality afforded by factory production, and more flexibility (financing, siting, sizing, and end-use applications) compared to larger nuclear power plants. The modular design concept allows for additional capacity to be added incrementally as demand for energy increases.

SMNRs offer the advantage of lower initial capital investment, scalability, and siting flexibility at locations unable to accommodate traditional larger reactors. SMNRs also have the potential for enhanced safety and security.

SMNRs are currently under development in many countries. The concepts span a range of technologies that can be classified into the following reactor types: (1) light-water cooled reactors (LWRs), (2) heavy-water cooled and moderated reactors (HWRs), (3) high-temperature gas-cooled reactors (HGTRs), (4) molten salt reactors (MSRs), and (5) fast neutron spectrum reactors. Section 3 through 7 of this report discuss SMNR concepts currently under development for each of the reactor types. This section discusses the types of nuclear power plants currently deployed worldwide, specific safety/security features that drive up the cost of NPPs, and several specific features that are being incorporated into SMNRs to reduce their cost relative to large NPPs and to improve the competitiveness of nuclear power relative to other forms of energy production.

### 2.1 Current Deployed Nuclear Reactor Fleet

As of March 2016, there are 436 NPPs operating worldwide having a total net electrical capacity of 379 gigawatt-electric (GW<sub>e</sub>) (ANS March 2016). Over 80% of these NPPs, representing almost 90% of the electrical capacity of all NPPs, are LWRs. There are primarily two types of LWRs deployed throughout the world: (1) pressurized-water reactors (PWRs) and (2) boiling water reactors (BWRs)<sup>3</sup>. PWRs by far constitute the majority of the nuclear power plants deployed around the world. As of March 2016, 280 NPPs operating worldwide, or 64%, were PWRs; these operating PWRs have a total electrical capacity of 262 GW<sub>e</sub>, representing 69% of all operating NPPs (ANS March 2016). BWRs represent the second most

---

<sup>3</sup> A third type of LWR is the supercritical water reactor (SCWR). The SCWR system is a high-temperature, high-pressure water-cooled reactor that operates above the thermodynamic critical point of water (374°C, 22.1 MPa). An SCWR has never been built or demonstrated. No known SCWRs currently under development meet the definition of a SMNR, and so SCWRs are not considered further in this study. See [https://www.gen-4.org/gif/jcms/c\\_40679/technology-system-scowr](https://www.gen-4.org/gif/jcms/c_40679/technology-system-scowr) for additional information on the development status of SCWRs.

common type of nuclear reactor deployed around the world. As of March 2016, 78 NPPs operating worldwide, or 18%, were BWRs; these operating BWRs have a total electrical capacity of 75 GW<sub>e</sub>, representing 20% of all operating NPPs (ANS March 2016).

In a PWR, the primary coolant/moderator (water) is circulated under high pressure (about 15.5 MPa) through the nuclear reactor where it is heated up (but does not boil). The heated water then flows through a steam generator where its heat is transferred to a secondary coolant (also water) that boils and generates steam. The primary coolant water, which is slightly radioactive, is confined within a containment building, while the steam from the steam generators, which is non-radioactive, exits the containment building. After exiting the containment building, the steam is then generally passed through a turbine that is connected to a generator to produce electricity. The residual steam is then condensed back to water, which is then returned to the containment building as coolant for the steam generators.

In a BWR, the coolant/moderator (water) is circulated through the nuclear reactor at a significantly lower pressure (about 7.6 MPa) than a PWR where it is heated up to the point that it boils and generates steam. The steam, which is slightly radioactive, exits the containment building where it is then generally passed through a turbine that is connected to a generator to produce electricity. The residual steam is then condensed back to water, which is then returned to the containment building as coolant for the reactor.

The fuel in LWRs is generally low-enriched uranium (LEU) oxide (UO<sub>2</sub>) having a U-235 content of less than 5%, although some LWRs use mixed-oxide fuel (MOX) composed of a mixture of plutonium recycled from used nuclear fuel and uranium. LWRs are generally refueled once every 12 to 24 months by replacing 25 – 33% of the fuel assemblies, of the total of 150 to 250 fuel assemblies in a PWR or 800 fuel assemblies in a BWR, in the reactor core.

As of March 2016, 48 NPPs operating worldwide, or 11%, were pressurized HWRs; these operating HWRs have a total electrical capacity of 24 GW<sub>e</sub>, representing 6% of all operating NPPs (ANS March 2016). In a pressurized HWR, the primary coolant/moderator (heavy water or deuterium oxide or D<sub>2</sub>O) is circulated under high pressure (about 11 – 12 MPa) through the nuclear reactor where it is heated up (but does not boil). The balance of the pressurized HWR plant is very similar to a PWR. The heated heavy water flows through a steam generator where its heat is transferred to a secondary coolant (water) that boils and generates steam. The primary coolant water, which is slightly radioactive, is confined within a containment building, while the steam from the steam generators, which is non-radioactive, exits the containment building. After exiting the containment building, the steam is then generally passed through a turbine that is connected to a generator to produce electricity. The residual steam is then condensed back to water, which is then returned to the containment building as coolant for the steam generators.

The fuel in pressurized HWRs is generally natural (not enriched) uranium oxide (UO<sub>2</sub>). Because of the use of natural uranium, pressurized HWRs are generally refueled daily by replacing about eight fuel bundles, of the total of 460 fuel bundles, in the reactor core.

There are no HTGRs or MSRs currently operating anywhere in the world. However, as of March 2016, 14 gas-cooled reactors (GCRs) are currently operating worldwide, all of them in the United Kingdom (ANS March 2016). There are also 15 graphite-moderated, water-cooled reactors (RBMKs) currently operating worldwide, all of them in the Russian Federation (ANS March 2016). These two reactor types,

which represent 7% of all NPPs, have a total electrical capacity of 18 GWe, representing 5% of all operating NPPs (ANS March 2016). Since SMNRs are not being developed utilizing either of these two reactor technologies, no further discussion of these reactor types is included here.

As of March 2016, there is only one fast neutron spectrum reactor operating worldwide (BN-600 reactor), and it is located in the Russian Federation<sup>4</sup>. It has an electrical capacity of 0.6 GWe (ANS March 2016). In this reactor, the primary coolant (liquid sodium metal) is circulated at a low pressure (a little higher than atmospheric or 0.1 MPa) through the nuclear reactor where it is heated up. The heated liquid sodium flows through an intermediate heat exchanger where its heat is transferred to a secondary coolant (also liquid sodium). This heated secondary circuit liquid sodium then flows through a steam generator where its heat is transferred to a tertiary coolant (water) that boils and generates steam. The primary circuit coolant liquid sodium, which is slightly radioactive, is confined within a containment building, while the secondary circuit liquid sodium from the intermediate heat exchangers, which is non-radioactive, exits the containment building. After exiting the containment building, this liquid sodium passes through the steam generator where it is then returned to the containment building as coolant for the intermediate heat exchangers. The steam in the tertiary circuit is passed through a turbine that is connected to a generator to produce electricity. The residual steam is then condensed back to water, which is then circulated back as coolant for the steam generators.

The fuel in the BN-600 is enriched UO<sub>2</sub>, having a U-235 content of 17 – 26%, although it can be fueled with MOX composed of a mixture of plutonium and uranium. The BN-600 is generally refueled twice a year by replacing about 33% of the fuel assemblies, of the total of 369 fuel assemblies, in the reactor core in each refueling.

## 2.2 Nuclear Power Cost Drivers

Since over 80% of the currently deployed NPPs worldwide are LWRs, this section focuses on the features of these NPPs that are the major factors that establish the levelized cost of electricity (LCOE) from nuclear power. LCOE represents the per-kilowatt-hour (kW-hr) cost of building and operating a nuclear power plant over its assumed design life (generally assumed to be 60 years). Key inputs to calculating LCOE include capital costs, fuel costs, fixed and variable operations and maintenance (O&M) costs, financing costs, and an assumed capacity factor. The major factors that drive the cost of nuclear power are as follows:

- The fuel used in operating LWRs is comprised of UO<sub>2</sub> pellets clad in a zirconium alloy metal. In the event of a loss-of-coolant accident (LOCA) in which the fuel is no longer covered by the water coolant, the decay heat in the fuel will eventually increase the temperature of the fuel cladding to the point the fuel will catastrophically fail (i.e., melt). This will result in the uncontrolled release of large quantities of radioactive materials into the containment building. For this reason, expensive, redundant safety systems must be incorporated into the design of the plant to prevent or mitigate accidents that could lead to core damage. Redundant safety systems include reactivity control systems, emergency coolant injection systems and decay heat removal

---

<sup>4</sup> A second fast neutron spectrum reactor using liquid sodium metal coolant (BN-800) is reported to have started commercial operation in the Russian Federation in 2016.

systems (referred to as emergency core cooling systems or ECCSs), and associated redundant instrumentation and control systems and support systems (e.g., emergency diesel generators, emergency batteries).

- Continuing with the previous bullet, the temperature of the fuel cladding will increase to the point that the zirconium will chemically react with the steam and generate large quantities of hydrogen gas. Large quantities of hydrogen pose an explosion risk that could damage the containment building sufficiently to release large quantities of radioactive materials to the environment. For this reason, a large robust/strong reinforced concrete containment building is required to prevent the release of large quantities of radioactive materials to the surrounding environment and public.
- As identified previously, LWRs are required to have ECCSs to remove decay heat from the reactor in the event the main cooling system is not available (such as from a loss-of-offsite-power event or a LOCA). The ECCS generally has many “active” electrical and mechanical components that require operator actions to fulfill their safety function of providing cooling to the reactor and removing decay heat. There is a significant operator resource requirement associated with maintaining and operating the ECCSs.
- NPPs are considered potential targets for terrorist attacks and sabotage, especially since the September 11, 2001 terrorist attacks on the World Trade Center in New York City. Large, well-equipped and well-trained security forces are required to protect NPPs from potential security threats.
- New, large LWRs in the U.S. and Europe have been taking 6-8 years or longer to construct and commission<sup>5</sup>. This long time period substantially increases financing costs and the risk of cost escalation/inflation.

## **2.3 Common Features of SMNRs that Increase Safety and Reduce Cost**

Most of the SMNRs evaluated in this report are being designed specifically to address the cost drivers identified in the previous section, and to further improve the safety of NPPs by significantly reducing the likelihood of or eliminating the possibility of severe accidents that release large quantities of radioactive materials. Some of the enhanced design features include:

- Incorporating much of the reactor coolant system (e.g., reactor pressure vessel and core, pressurizer, reactor coolant pumps, control rod drive mechanisms, steam generators, associated piping) within the reactor pressure vessel (RPV) or attached to the outside of the RPV. The small size of SMNRs, and technology advancements with RCS components such as the steam generators, makes a compact reactor coolant system (RCS) possible. A compact RCS

---

<sup>5</sup> This time period is even longer, by 2 to 4 years, after accounting for the time to receive regulatory approval of the site and of the reactor design.

significantly reduces or, in some designs, eliminates the potential for large break LOCAs that can rapidly lead to core damage.

- Incorporating passive safety features into the design of the ECCSs.
  - Passive safety features include natural circulation of the primary coolant in the event of a loss-of-power, thereby eliminating the need for expensive, redundant safety-related ECCSs that require significant operator and maintenance resources. Current operating NPPs typically have a grace period of 4-6 hours in a station blackout event (i.e., a total loss of power to the plant) before the emergency batteries are depleted and core damage results because power is required to operate the coolant pumps to provide forced circulation of the coolant. SMNRs extend the grace period to days, weeks, or even indefinitely in some designs through the use of natural circulation of the coolant that does not require operator intervention or emergency AC/DC power. The longer the grace period, the more time available to obtain additional resources if necessary to bring the reactor to a safe shutdown condition.
  - Another passive safety feature being incorporated in SMNR designs is installing the RPV/containment vessel inside a vault containing a large coolant reservoir. The reservoir provides supplemental or backup cooling of the reactor in the event of a loss of primary coolant (LOCA), such as may result from coolant boil-off from overheating.
- Incorporating inherent safety features that take advantage of natural physical laws to eliminate the possibility of accidents that result in core damage. An inherent safety feature of some SMNR designs is to use near fail-safe nuclear fuel that cannot catastrophically fail (i.e., melt) under any accident scenario<sup>6</sup>. Near fail-safe fuel has a melting temperature that is significantly higher than the maximum temperature possible under all identified accident scenarios.
- Significantly reducing the size of the containment building, which substantially reduces the cost of the containment structure. In some cases, the containment building structure is eliminated and replaced by a compact containment vessel. In addition, the small size has the added benefit of allowing the containment structure/vessel to be placed below ground, thus reducing a potential security vulnerability by providing added protection against aircraft impacts and acts of terrorism.
- The simplified designs of many SMNRs are expected to reduce the time for construction and commissioning to 3 – 5 years, from the 6 – 8 years or longer with current operating NPPs.
- Many SMNRs are being designed to be deployed in NPPs composed of multiple modules, ranging from one module to 12 modules. The advantage of the modular approach is that modules can be added over time as demand for electricity/heat/etc. increases. The disadvantage is that a single or small number of modules at a single site will not benefit from the economies-of-scale of

---

<sup>6</sup> The term “near fail-safe” is used because the fuel can potentially fail as a result of fabrication defects, mistreatment, etc., that result in small releases of radioactive material.

installing a large NPP at a single site<sup>7</sup>. To offset this cost disadvantage, SMNRs are being designed to have all of the modules at the NPP be operated from a single control room, and to have a single senior reactor operator (SRO) responsible for the operation of multiple reactor modules. This operation strategy is not currently allowed and will need to be approved by the regulator.

## 2.4 SMNR Decommissioning

Generally, as with new large baseload NPPs, most of the SMNRs are being designed for operating lives of up to 60 years, and even longer in some cases. However, when the SMNR has been permanently shutdown and is to be decommissioned, each SMNR type poses different and unique challenges. There is a significant amount of experience with decommissioning iPWR-type reactors, including long-term storage of used nuclear fuel and final disposal of radioactively-contaminated materials<sup>8</sup>. This is because iPWRs use similar fuel and have similar reactor components/materials as used in NPPs in common use today, of which many have been fully decommissioned and dismantled.

There is significantly less decommissioning and dismantlement experience with HWRs and HTGRs, which can potentially contain significant quantities of the isotope Carbon-14, which requires specialized treatment to ensure long-term isolation after final disposal. Finally, there is little or no decommissioning and dismantlement experience with the other reactor types (i.e., MSRs, SFRs, GFRs, and HLMC fast reactors). These reactor types use non-standard coolant materials that, in some cases, are highly pyrophoric or toxic and so require specialized treatment for final disposal. For all of the SMNR types, however, final disposition of the used nuclear fuel produced during the operating life of the plant poses regulatory and political challenges that have not been fully resolved by any country to-date. On the other hand, long-term interim storage of used nuclear fuel has been demonstrated and is expected to be safe for 100+ years.

---

<sup>7</sup> However, the unit cost of each SMNR module will decline as the number of SMNRs deployed increases, which will offset some of the economies-of-scale benefits of large NPPs.

<sup>8</sup> For example, large NPPs in the U.S. that have completed decommissioning and dismantlement include Haddam Neck, Maine Yankee, Rancho Seco, Trojan, and Yankee Rowe.



### 3.0 Integral Pressurized-Water Reactors

LWRs generally include two types of reactors: PWRs and BWRs. This section only assesses small modular PWRs, referred to as integral pressurized-water thermal-neutron reactors (iPWRs). The reason for this is that most small modular light water reactors currently under development are of the PWR type, primarily because the high pressure of the primary coolant system (PCS) allows for smaller coolant inventory and therefore a more compact reactor and smaller RPV than a corresponding BWR of the same thermal/electrical capacity. Another reason is that no small modular BWRs appear to be actively under development<sup>9</sup>.

An iPWR combines all or many elements of the PCS into a single assembly that, in some cases, also provides the primary containment function in the event of a core-damage accident. The major elements of the PCS include the reactor core or reactor pressure vessel (RPV), reactor coolant pumps, pressurizer, steam generator, and control rod drive mechanisms (CRDMs). Incorporating each of these elements within a single assembly significantly improves safety by, depending on the design, eliminating certain design-basis accidents that must be considered in the design of PWRs, such as 1) large break loss of coolant accidents and 2) control rod ejection loss of coolant accidents. In addition, combining the PCS elements into a single assembly (that is small relative to current generation PWRs) allows for a much smaller primary containment vessel (or building) than with current-generation PWRs.

Most of the iPWR concepts evaluated in this study are heavily based on existing PWR reactor/fuel technology that is intended to accelerate their development (i.e., take maximum advantage of past PWR experience and testing) and ease the necessary design approval from the regulator. As with any technology, iPWRs have both advantages and disadvantages. In addition to the general advantages of SMNRS discussed in Section 1.1, specific advantages of iPWRs include:

- Potential safety benefits include eliminating large-break loss-of-coolant accidents (LOCAs) due to a ruptured pipe, very long or even indefinite time periods to respond to loss of offsite power (from use of natural circulation and large water reservoirs for cooling), and reduced potential for transients that trip the reactor offline (because of fewer active components);
- Improved public acceptance of nuclear power due to the elimination of or significant reduction in the quantity of radioactive material (or source term) released during an accident, which would support elimination of or significant reduction in the Emergency Planning Zone (EPZ);
- Reduced financial risk compared to large nuclear power plants due to much smaller and simpler designs (i.e., elimination of safety-related emergency diesel generators, elimination of large containment building), and ability to add additional capacity in smaller increments;
- Capable of being used for either baseload or load-following (non-baseload) operation; and

---

<sup>9</sup> PNNL is aware of two SMNRS of the BWR type that have been under development in the past, but further development appears to have stalled for unknown reasons (likely because of no expressed interest by potential buyers). These are the VK-300 being developed by N.A. Dollezhal Research and Development Institute of Power Engineering (NIKIET) [Russian Federation] and the Modular Simplified and Medium Small Reactor (DMS) by Hitachi-GE Nuclear Energy [Japan]. See the reference IAEA September 2014 for additional information on these reactor concepts.

- Can be configured for co-generation of electricity, steam for district heating, and/or for desalination of water.

In addition to the general disadvantages of SMNRS discussed in Section 1.1, specific disadvantages of iPWRs include:

- The integral RPV or containment vessel potentially increases the complexity of refueling operations (e.g., requires more components to be removed/reinstalled during refueling) and potentially complicates repair/inspection operations;
- The integral components, such as steam generators, are exposed to a higher intensity radioactive environment than with larger NPPs, also potentially complicating repair/inspection operations; and
- The steam generation quality (pressure and temperature) is not suitable for use in many process heat applications generally and for SAGD operation specifically (the temperature and pressure of the steam are less than 315°C and 9 MPa, respectively).

A range of different iPWR concepts were selected for review to allow appropriate comparison of the various factors identified in Appendix A. A few of the concepts are clearly at a development stage less than the Technology Readiness Level (TRL) of 5 in which the design and performance of major reactor components have been validated in a relevant environment. These are included because the concept is either a well-known and much discussed concept in the international nuclear community or has unique design features that may be of interest (i.e., precludes on-site refueling or fuel handling). A brief description of each iPWR evaluated in this study and its development status is provided below.

### 3.1 Small iPWR Concepts

#### *ACP-100 by China National Nuclear Corporation (CNNC) [People's Republic of China]*

The ACP-100 is an iPWR having a design electrical/thermal capacity of 100 MW<sub>e</sub>/310 MW<sub>th</sub>. The RPV contains the reactor core and steam generators. The pressurizer (PRZ), reactor coolant pumps (RCPs), and control rod drive mechanisms are located outside of the RPV. The RPV, pressurizer, reactor coolant pumps, and control rod drive (CRD) mechanisms are surrounded by a containment building. The ACP-100 plant design will allow the deployment of one to eight modules to attain larger plant output as demands arise. Figure 3.1-1 provides a conceptual drawing of the ACP-100 reactor.

The reactor core is cooled by the forced circulation of the cooling water during normal plant operation. Passive safety features allow for the passive removal of decay heat for 72 hours without safety-related emergency alternating current (AC) power and 72-hour safety-related direct current (DC) power supply. The containment building and spent fuel pool are located underground for protection against aircraft impact.

The first ACP-100 plant is planned to be constructed at a site in Putian City, Fujian Province, China. The schedule for design certification by the national regulator and for construction is unknown, and is revised every year. However, much of the required component and integrated system testing appears to have

been completed. Based on this, the ACP-100 is judged to have a TRL of 5-6 and an estimated commercialization time window of 5-10 years.

Additional information about the ACP-100 can be found in the following references: IAEA 2014, IAEA June 2013, IAEA September 2013, and IAEA 2015a.

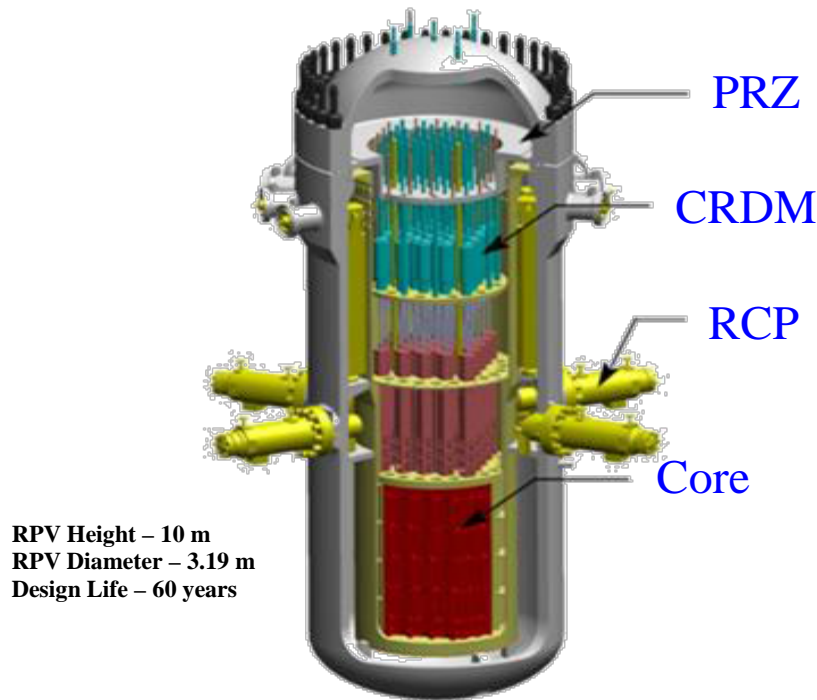

Figure 3-1. Conceptual Drawing of ACP-100 Reactor

***mPower™ by Babcock and Wilcox (B&W) Generation mPower™ [USA]***

The mPower™ is an iPWR having a design electrical/thermal capacity of 180 MWe/530 MW<sub>th</sub>. The integral RPV contains the reactor core, pressurizer, steam generator, reactor coolant pumps, and control rod drive mechanisms. The RPV is surrounded by a modest-sized containment building. The mPower™ plant design will allow the deployment of one to two modules to attain larger plant output as demands arise. Figure 3.1-2 provides a conceptual drawing of the mPower™ reactor module and two-module plant.

The reactor core is cooled by the forced circulation of the cooling water during normal plant operation. Passive safety features allow for the passive removal of decay heat for 72 hours without safety-related emergency AC power and 72-hour safety-related DC power supply. The containment building, spent fuel pool, and main control room are located underground for protection against aircraft impact.

Submission of the design certification application to the Nuclear Regulatory Commission (NRC) was delayed indefinitely in 2014 with design activities significantly slowed. However, B&W announced in

March 2015 that development of the mPower™ reactor would be accelerated. No new date has been announced for submission of the design certification application nor has a schedule been announced for the design and construction of the first mPower™ plant. Some component testing has been completed, but much remains to be performed. Based on this, the mPower™ is judged to have a TRL of 5-6 and an estimated commercialization time window of 10-15 years.

Additional information about mPower™ can be found in the following references: IAEA 2014, IAEA September 2013, NEI 2013, B&W 2010, and R&D Caucus 2012.

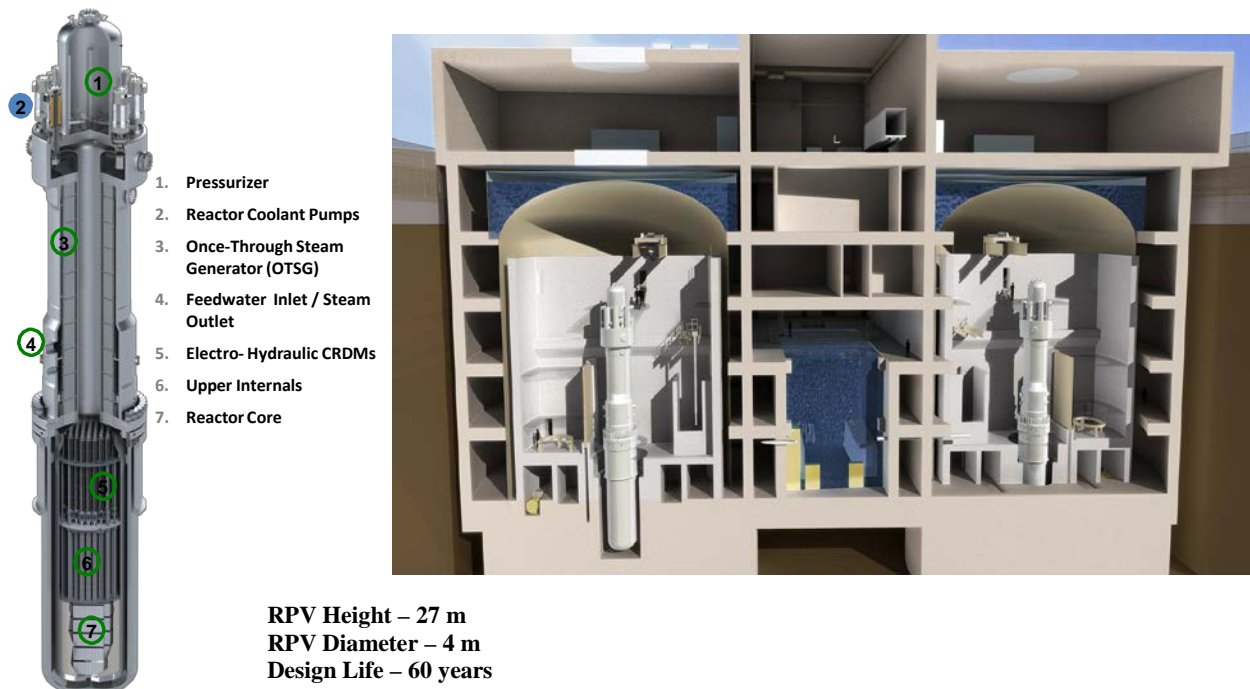

Figure 3-2. Conceptual Drawing of the mPower™ Reactor Module and Two-unit Plant

***CAREM-25 by Comisión Nacional de Energía Atómica (CNEA) [Argentina]***

The CAREM-25 is an iPWR having a design electrical/thermal capacity of 27 MW<sub>e</sub>/100 MW<sub>th</sub>. The integral RPV contains the reactor core, pressurizer, steam generators, and control rod drive mechanisms. Cooling during normal plant operations is by natural circulation and so there are no reactor coolant pumps. The RPV is surrounded by a containment building. Each plant is designed to contain a single reactor module. Figure 3.1-3 provides a conceptual drawing of the CAREM-25 reactor.

The reactor core is cooled by the natural circulation of the cooling water during normal plant operation, however the larger scaled-up plant (150-300 MWe) planned for export may require forced circulation (i.e., use of reactor coolant pumps). Passive residual heat removal system allows for the passive removal of decay heat for 36 hours due to either station blackout (SBO) or loss of heat sink without AC power or

operator actions. Some minimal active systems are required for SBOs longer than 36 hours. The reactor is located above ground.

The prototype CAREM-25 reactor has received design approval from the Argentine regulator, and is currently under construction at a site near the city of Zárate, in the northern part of Buenos Aires province next to the Atucha I Nuclear Power Plant<sup>10</sup>. Reactor startup is planned for 2017. There is no documented indication of a public siting process being used. Some component testing has been completed, while fuel irradiation testing and testing of the hydraulic CRDs remains to be performed. Based on this, the CAREM-25 is judged to have a TRL of 5-6 and an estimated commercialization time window of 5-10 years.

Additional information about CAREM-25 can be found in the following references: IAEA 2009a, IAEA 2014, WWN 2014, and LAS/ANS 2014.

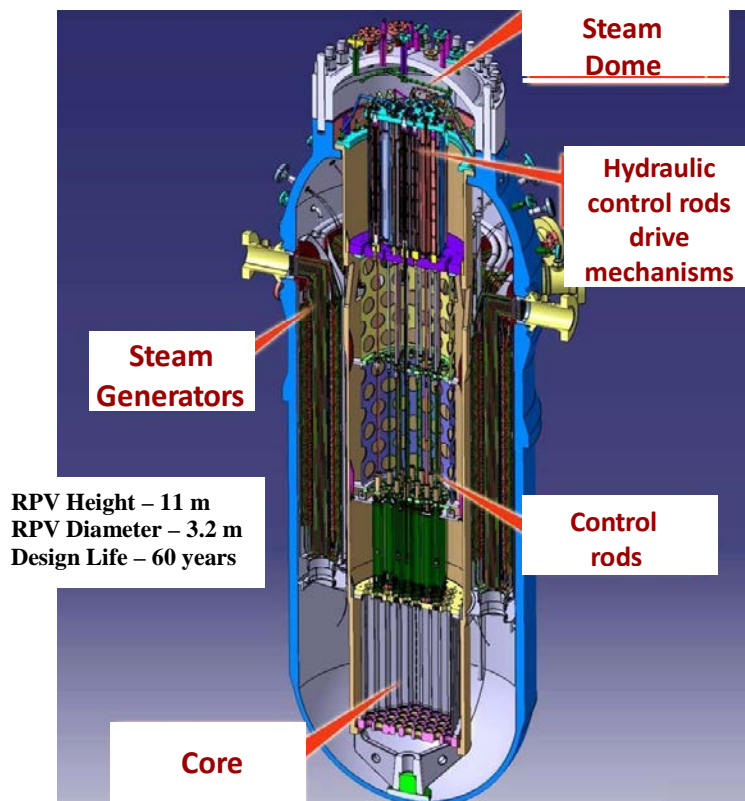

Figure 3-3. Conceptual Drawing of the CAREM-25 Reactor

<sup>10</sup> No official announcement has ever been made regarding the basis for the decision to site the CAREM-25 reactor at the same site as the larger Atucha-1 (335 MW<sub>e</sub>) and -2 (692 MW<sub>e</sub>) plants. However, given the relatively small size of the CAREM-25 reactor, it is likely that the Atucha site was selected because it is one of only two sites in Argentina having operating nuclear power plants (the other being the Embalse Unit 1 site) and the associated large existing nuclear power plant work force.

***FBNR (Fixed Bed Nuclear Reactor) by Federal University of Rio Grande do Sul (FURGS) [Brazil]***

The FBNR is an iPWR having a design electrical/thermal capacity of 72 MW<sub>e</sub>/218 MW<sub>th</sub>. The integral RPV contains the reactor core and steam generator. The pressurizer and reactor coolant pump are located outside the RPV. There is a single fixed control rod in the center of the suspended fixed bed core so CRDs are not used. The RPV is surrounded by a containment building. Figure 3.1-4 provides a conceptual drawing of the FBNR.

The FBNR is a unique PWR concept that deviates substantially from the PWR reactor design concepts evaluated elsewhere in this study (i.e., has a suspended fixed bed core and utilizes CERMET UO<sub>2</sub>), and is currently only in the very early concept development stage. It is included in this assessment because of a design goal to improve safeguards and proliferation resistance by eliminating on-site refueling of the reactor (all other iPWR design concepts and most non-iPWR design concepts evaluated in this study include on-site refueling).

The reactor core (fuel elements) is suspended by the flowing forced circulation of cooling water. When the reactor coolant pump is turned off the fuel elements fall into a passively cooled fuel chamber. Passive safety features allow for the passive removal of decay heat indefinitely (at least one month) without safety-related emergency AC power or operator actions.

There appears to have been no component or fuel testing to-date. Further development appears to be at a very slow pace. Based on this, the FBNR is judged to have a TRL of 1-2 and an estimated commercialization time window of 20+ years.

Additional information about FBNR can be found in the following references: IAEA 2009b, IAEA January 2011, and IAEA September 2012.

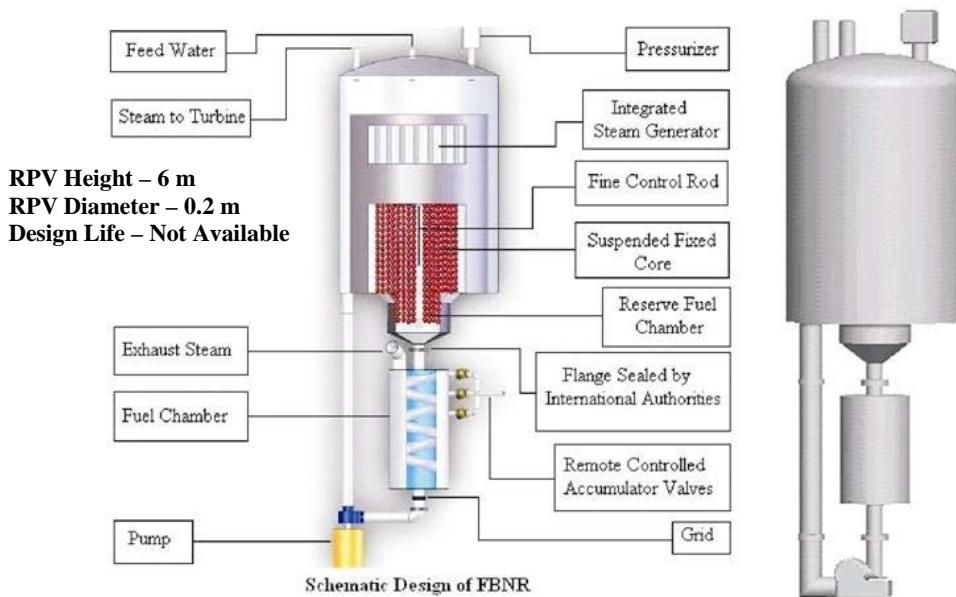

Figure 3-4. Conceptual Drawing of the FBNR

### ***SMR-160 by Holtec International [USA]***

The SMR-160 is an iPWR having a design electrical/thermal capacity of 160 MW<sub>e</sub>/525 MW<sub>th</sub>. The integral RPV contains the reactor core in a configuration that is offset from the integral steam generator and pressurizer. The control rod drive mechanisms are located outside the RPV. Cooling during normal plant operations is by natural circulation and so there are no reactor coolant pumps. The offset configuration is intended to simplify refueling operations relative to other iPWR designs. The RPV and integral steam generator/pressurizer are surrounded by a modest-sized containment building. Each plant is designed to contain a single reactor module. Figure 3.1-5 provides a conceptual drawing of the SMR-160 reactor module and plant.

The reactor core is cooled by the natural circulation of the cooling water during normal plant operation. Passive safety features allow for the passive removal of decay heat for an unlimited time period without safety-related emergency AC power, additional water, or operator actions. The RPV and spent fuel pool are located underground while the integral steam generator/pressurizer is located partially above ground.

No schedule has been announced for submission of the design certification application to the NRC. Furthermore, there has been no published schedule for the performance of component/fuel testing. However, a testing facility is currently under construction by Holtec International as of July 2015. Based on this, the SMR-160 is judged to have a TRL of 2-3 and an estimated commercialization time window of 10-15 years.

Additional information about SMR-160 can be found in the following references: IAEA 2014, SSEB 2012, Holtec International 2014, Holtec International 2015, and Platts 2013.

### ***IRIS by an International Consortium (mostly Italy, but originally Westinghouse)***

The IRIS (International Reactor Innovative and Secure) is an iPWR having a design electrical/thermal capacity of 335 MW<sub>e</sub>/1000 MW<sub>th</sub>. The integral RPV contains the reactor core, pressurizer, steam generators, reactor coolant pumps, and CRD mechanisms.

While this reactor concept has received much international attention over the years, it is not considered a candidate for further consideration in this study. The IRIS reactor concept appears is no longer being pursued since no new information is available in the last few years and the official IRIS website has ceased operation.



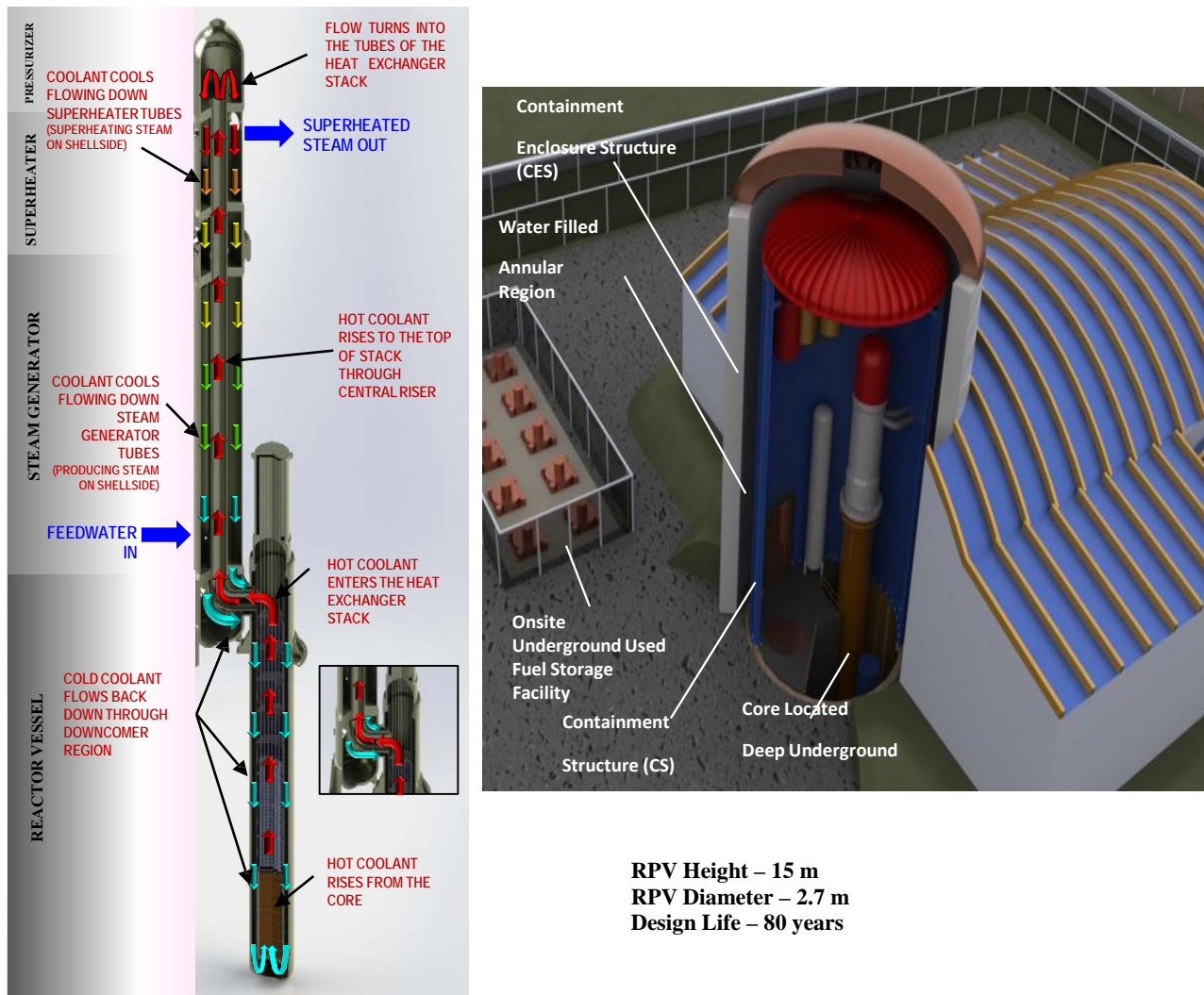

Figure 3-5. Conceptual Drawing of SMR-160 Reactor Module and Plant

***NuScale by Nuscale Power, LLC [USA]***

The NuScale is an iPWR having a design electrical/thermal capacity of 45 MW<sub>e</sub>/160 MW<sub>th</sub>. The integral RPV contains the reactor core, pressurizer, and steam generators. The RPV and CRDMs are housed within an integral containment vessel. Cooling during normal plant operations is by natural circulation and so there are no reactor coolant pumps. The NuScale plant design will allow the deployment of one to twelve modules to attain larger plant output as demands arise. Figure 3.1-6 provides a conceptual drawing of the NuScale reactor module and plant.

The reactor core is cooled by the natural circulation of the cooling water during normal plant operation. Passive safety features allow for the passive removal of decay heat for an unlimited time without safety-related emergency AC or DC power or additional water or operator actions. The reactor pool (including the integral RPV and containment vessel), spent fuel pool, and main control room are located underground for protection against aircraft impact.



The design certification application to the Nuclear Regulatory Commission (NRC) is planned to be submitted in December 2016, however, the NRC staff has already expended several thousand person-hours on pre-application review of the NuScale design. Much of the required component testing has been completed, although testing is continuing on the CRDMs and fuel assemblies. Construction of the first NuScale plant on the Idaho National Laboratory site in Idaho, U.S. is expected to begin in 2019 and to start operation in 2023. Based on this, the NuScale is judged to have a TRL of 5-6 and an estimated commercialization time window of 5-10 years.

Additional information about NuScale can be found in the following references: IAEA 2014, IAEA 2015b, ANS 2015a, Nuclear Energy Insider 2016, NuScale Power 2016, and ASME 2014.

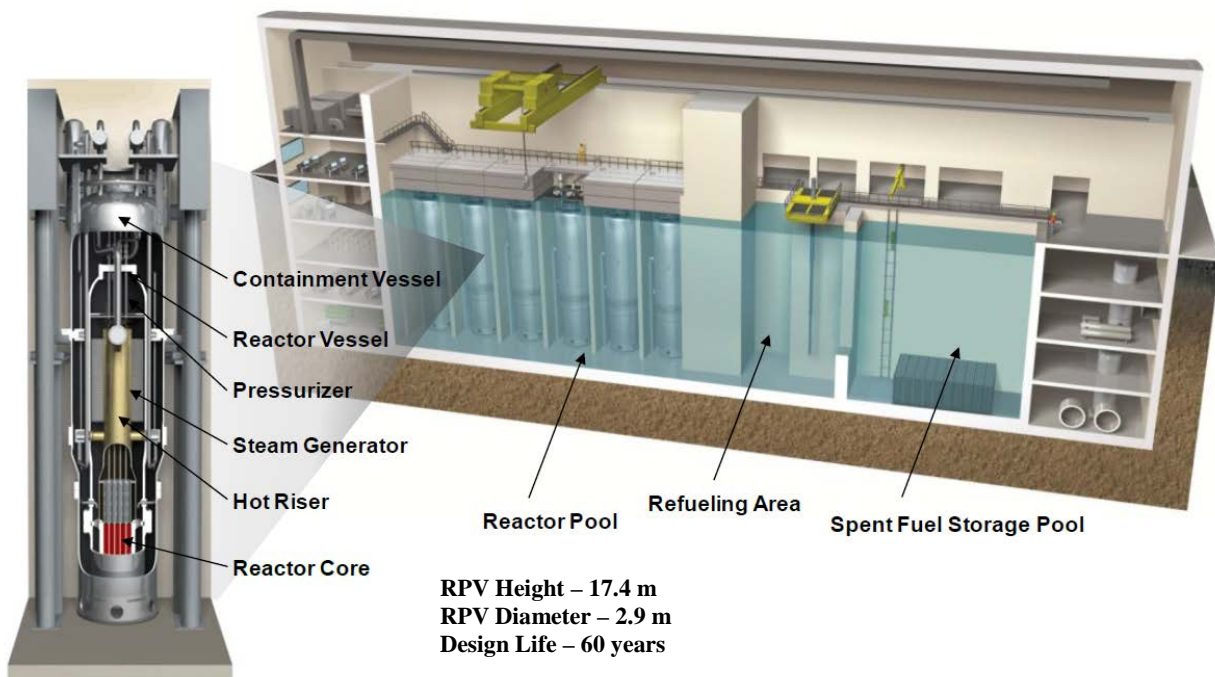

Figure 3-6. Conceptual Drawing of NuScale Reactor Module and Plant

***RITM-200 by OKBM Afrikantov [Russian Federation]***

The RITM-200 is an iPWR having a design electrical/thermal capacity of 50 MW<sub>e</sub>/175 MW<sub>th</sub>. The integral RPV contains the reactor core and steam generators. The reactor coolant pumps, pressurizer, and CRD mechanisms are external to the RPV and, hence, additional water injection systems are provided to mitigate the consequences of a large LOCA.

This reactor concept is claimed to be designed for multipurpose use in icebreakers, floating NPPs, and land-based NPPs. However, because the literature only describes its use for providing propulsion for icebreakers, it is not considered a candidate for further consideration in this study. Two RITM-200

reactors are currently under construction with a planned delivery in 2016 and installation in two different ice-breakers in 2017 and 2018.

***SMART (System-integrated Modular Advanced Reactor) by Korea Atomic Energy Research Institute (KAERI) [Republic of Korea]***

The SMART is an iPWR having a design electrical/thermal capacity of 100 MW<sub>e</sub>/330 MW<sub>th</sub>. The integral RPV contains the reactor core, pressurizer, steam generators, and reactor coolant pumps. The CRD mechanisms are located outside the RPV. The RPV and CRD mechanisms are surrounded by a large containment building. Each plant is designed to contain a single reactor module. Figure 3.1-7 provides a conceptual drawing of the SMART reactor.

The reactor core is cooled by the forced circulation of the cooling water during normal plant operation. Passive safety features allow for the passive removal of decay heat for 36 hours without safety-related emergency AC power or operator actions. The reactor is located above ground, similar to current-day PWRs.

Standard Design Approval was received from the Korean nuclear regulatory on July 4, 2012. The reactor is being actively marketed. Saudi Arabia has expressed interest in hosting the first plant, however no sales have yet been announced. All component and fuel testing necessary to receive the design approval have been completed. Based on this, the SMART is judged to have a TRL of 6-7 and an estimated commercialization time window of 0-5 years.

Additional information about SMART can be found in the following references: IAEA 2011 and IAEA 2014.

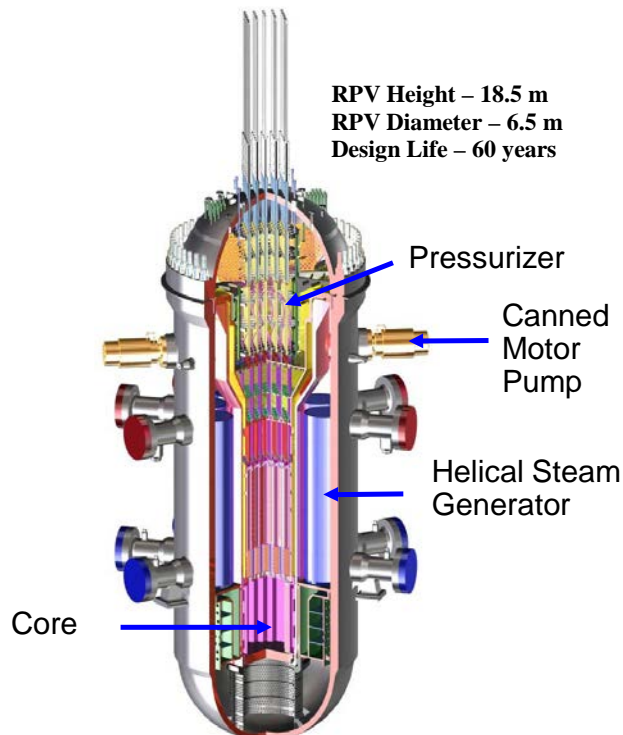

Figure 3-7. Conceptual Drawing of SMART Reactor

*Westinghouse SMR by Westinghouse Electric Company, LLC [USA]*

The Westinghouse SMR is an iPWR having a design electrical/thermal capacity of 225 MW<sub>e</sub>/800 MW<sub>th</sub>. The integral RPV contains the reactor core, pressurizer, steam generators, and CRD mechanisms. The reactor coolant pumps are mounted on the outside of the RPV. The RPV and reactor coolant pumps are housed within an integral containment vessel. Each plant is designed to contain a single reactor module. Figure 3.1-8 provides a conceptual drawing of the Westinghouse SMR reactor module and plant.

The reactor core is cooled by the forced circulation of the cooling water during normal plant operation. Passive safety features allow for the passive removal of decay heat for seven days without safety-related emergency AC power, additional water, or operator actions. The reactor containment pool (including the integral RPV and containment vessel) and spent fuel pool are located underground for protection against aircraft impact.

The Westinghouse SMR design draws extensively on the passive technology of the AP1000 design, which has been reviewed and approved by the NRC and is currently under construction at locations in China and USA. No schedule has been announced for submission of the design certification application to the NRC. Furthermore, there has been no published schedule for the performance of component/fuel testing and Westinghouse announced in February 2014 that further development efforts have been canceled due to the lack of prospective customers and funding. However, it was announced in March 2015 that the NRC had approved the testing plan for the Westinghouse SMR, which will expedite design approval when the design certification application is submitted to the NRC. Based on this, the Westinghouse SMR is judged to have a TRL of 4-5 and an estimated commercialization time window of 10-15 years.

Additional information about Westinghouse SMR can be found in the following references: IAEA 2011, IAEA 2014, Westinghouse 2013, Westinghouse 2014, and Westinghouse 2015.

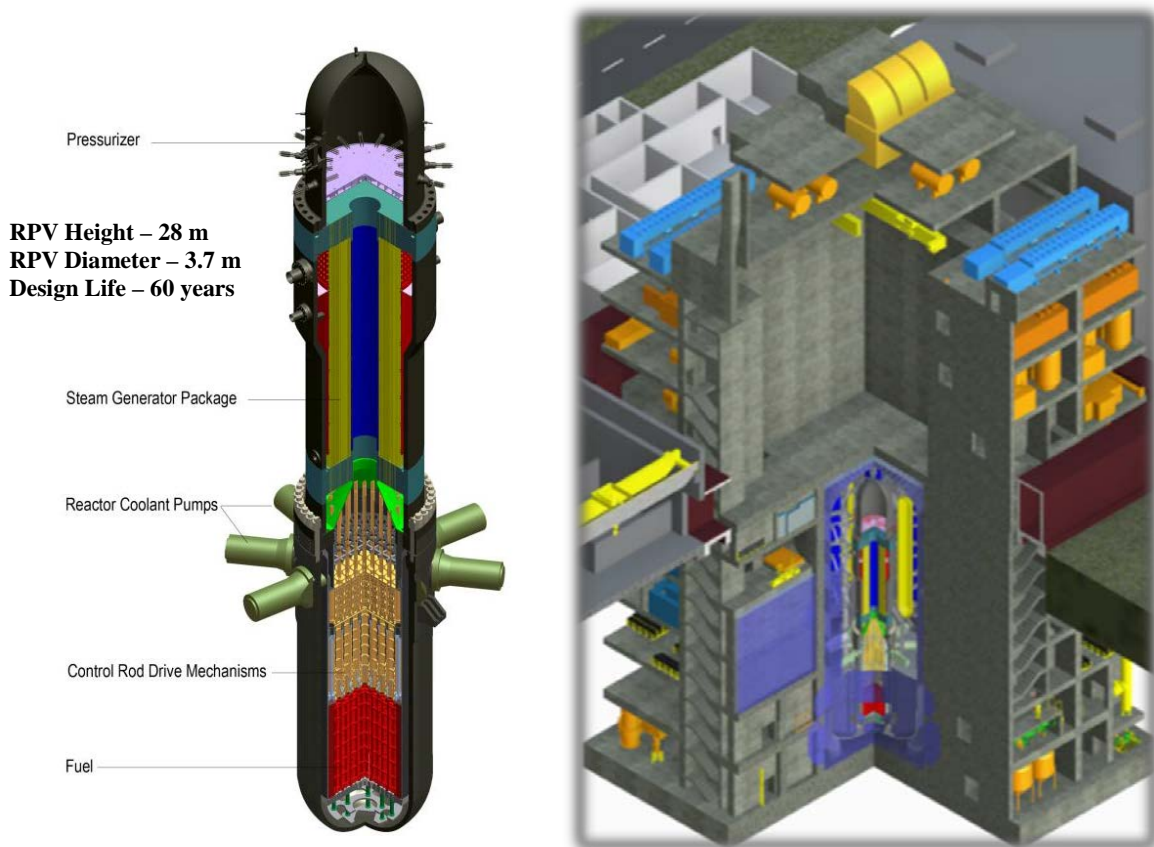

Figure 3-8. Conceptual Drawing of the Westinghouse SMR Reactor Module and Plant

### 3.2 Operational Experience with iPWRs

Approximately 280 PWRs used to generate electric power are currently in operation around the world with another 40+ PWRs permanently shutdown and no longer in service (ANS March 2016). While these represent tens of thousands of reactor years of operation, none of these PWRs incorporate the passive safety features of the iPWRs discussed in the previous section (e.g., passive removal of decay heat without safety-related emergency AC power, additional water, or operator actions for at least 36 hours, in the case of the CAREM-25 reactor, and up to an unlimited time, in the case of the NuScale reactor). Generally, these currently operating and shutdown PWRs require active emergency core cooling and decay heat removal systems within a few hours after a loss of power event to prevent core damage, and an even shorter time period for a large loss of coolant accident.

The safety significance of accidents or incidents (i.e., events) at nuclear power plants, or with the non-military use of radiological materials generally, are rated by the International Atomic Energy Agency (IAEA) using the International Nuclear and Radiological Event Scale (INES) Scale. Events are rated at seven levels with increasing significance from 1 to 7, where Levels 1-3 are “incidents” and Levels 4-7 are “accidents” (<http://www-ns.iaea.org/tech-areas/emergency/ines.asp>). The scale is designed such that the severity of an event is approximately ten times greater for each increase in level of the scale. Events without safety significance are rated as Below Scale/Level 0. Events that have no safety relevance with

respect to radiation or nuclear safety are not rated on the scale. For example, the Chernobyl NPP (Ukraine) accident in 1986 and the Fukushima Daiichi NPP accident (Japan) in 2011 are each rated as INES Level 7, “major accident,” because each involved a “major release of radioactive material with widespread health and environmental effects requiring implementation of planned and extended countermeasures.” Neither of these NPPs were PWRs<sup>11</sup>. On the opposite end of the scale, a steam explosion in the balance-of-plant (non-reactor) portion of the Mihama NPP (PWR in Japan) in 2004 that killed four workers is rated as INES Level 1, “incident” because it had minor impact on safety systems.

While the IAEA maintains a database of nuclear or radiological incidents, referred to as the Unified System for Information Exchange in Incidents and Emergencies (USIE), this database is only available to official Contact Points designated by IAEA Member States and so is not publicly available. Hence, a complete and thorough list of events having an INES rating is not readily available. However, various “non-official” sources have tabulated lists of major events on the INES scale, and these have been reviewed to identify the safety-related events at PWR NPPs classified as a Level 3 event, “serious incident,” or higher. With no assurance that the identified list of events is complete, these are as follows:

- Three Mile Island NPP Unit 2 (792 MWe) in USA (INES Level 5, “accident with wider consequences”). This 1979 event involved a relatively minor malfunction in the secondary cooling system that caused the reactor to automatically shutdown. However, a relief valve in the primary system failed to close, and instrumentation failed to reveal this fact, resulting in a loss of coolant accident (LOCA) when a substantial quantity of the coolant leaked out of the stuck-open relief valve. The accident continued for about one month and ended when the operators successfully placed the reactor into cold shutdown via natural convection circulation of the coolant. The consequence of the accident was a partial meltdown of the reactor core (about 45% of the fuel) and a relatively small release of fission products or radioactive material. Most of the melted fuel and fission products were retained in the containment building per design. Subsequently, sweeping changes were made to the regulation and operation of NPPs involving emergency response planning, reactor operator training, human factors engineering, radiation protection, and many other areas of nuclear power plant operations
- Nord or Greifswald NPP Unit 1 (408 MWe) in East Germany (INES Level 3, “serious incident”). This 1975 event involved a fire caused by operator error while the plant was operating that almost resulted in a loss of coolant accident (LOCA). As part of a training exercise, an electrician intentionally created a short-circuit on the primary winding of one of the Unit 1 pumps that resulted in a fire. The fire in the main trough destroyed the AC supply and the control lines of five of the six Unit 1 main coolant pumps that provide cooling to the Unit 1 reactor. The fire was quickly brought under control by the fire-brigade and the pumps were temporarily repaired. A few hours after the incident the IAEA was informed by Soviet Union authorities, which classified the accident as INES Level 4, which was later revised to INES Level 3. Subsequently, fire protection within the power station was substantially strengthened and separate electrical lines for each pump were installed so that a single fire could not impact all of the pumps.

---

<sup>11</sup> The Chernobyl NPP reactors were RBMK-type reactors. RBMK reactors are graphite-moderated, pressurized channel-type reactors designed by the former Soviet Union and exclusively built in countries of the former Soviet Union. The Fukushima Daiichi NPP reactors are boiling water reactors (BWRs) designed by the General Electric Co. and built in many countries around the world.

- Davis-Besse NPP Unit 1 (908 MWe) in USA (INES Level 3, “serious incident”). This 2002 event involved a significant degradation (due to corrosion) of the reactor vessel head that was identified by operators during an inspection of the vessel head during a refueling outage. An area roughly the size of a football was eroded from the carbon steel vessel head to a depth of more than six inches, leaving only about 3/8-inch thick stainless steel cladding to hold the high pressure (~17 MPa) of the reactor coolant. If not detected during the outage, the result could have been a large LOCA during reactor operation with the coolant leaking through the hole in the vessel head. The resulting corrective operational and system reviews and engineering changes took two years.

In addition, the U.S. NRC established the Accident Sequence Precursor (ASP) Program in 1979 to systematically evaluate U.S. NPP operating experience to identify, document, and rank the operating events that were most likely to have led to inadequate core cooling and severe core damage (precursors), accounting for the likelihood of additional failures. To identify potential precursors, the NRC staff reviews plant events from licensee event reports (LERs), inspection reports, and special requests from NRC staff. A review of these events since 1979 (NRC 2010) that are specific to PWR NPPs identified the following safety-significant operational events (in addition to the Three Mile Island NPP Unit 2 and Davis-Besse NPP events described above):

- Davis-Besse NPP Unit 1 (908 MWe). This 1985 event involved a loss of main feedwater (secondary side cooling) to the steam generators. In this event, the reactor automatically tripped offline when one of the main feedwater (MFW) pumps tripped (automatically shutdown for some reason) and the second MFW pump was unavailable. The operators made an error by isolating emergency feedwater (EFW) to both steam generators, resulting in the loss of decay heat removal capability. During the event, the power-operated relief valve (PORV) actuated three times and failed to reseal at the proper reactor coolant system (RCS) pressure. Unmitigated, this event would have resulted in a loss of coolant accident (LOCA). Operators closed the PORV block valves (i.e., isolated the “open” PORV), recovered EFW locally, and proceeded with normal shutdown of the plant.
- Shearon Harris NPP Unit 1 (973 MWe). This 1991 event involved an inoperable emergency core cooling system that would have prevented emergency injection of cooling water into the reactor core during a loss of coolant accident (LOCA). Unlike the previous events described, which are accident initiators, this event is a loss of an accident mitigation system that would not have been available in the event of separately-initiated LOCA. A degraded condition resulted from relief valve and drain line failures in the alternative minimum flow systems for the emergency cooling water injection pumps which would have diverted a significant amount of emergency cooling water injection flow away from the reactor coolant system. The root cause of the degradation is believed to have been water hammer, as a result of air left in the alternative minimum flow system following system maintenance and test activities.

Also, while the Fukushima Daiichi NPP accident (Japan) in 2011 (INES Level 7, “major accident”) was a boiling water reactor (BWR) rather than a PWR, this station blackout (SBO) event could just as well occur at a PWR NPP. The SBO was caused by a large earthquake-induced tsunami that exceeded the design basis for the plant, which rendered unavailable the offsite power and inoperable the NPP emergency diesel generators. While the NPP units were automatically shutdown as a result of the earthquake, the unavailability of power to operate the emergency core cooling system and decay heat

removal system components resulted in a large LOCA, meltdown of portions of three reactor cores, and a large release of fission products or radioactive material.

The iPWRs discussed in the previous section have been expressly designed to specifically preclude or to significantly reduce the likelihood of large LOCAs and to eliminate or significantly reduce the consequences of an SBO event. This is accomplished to varying degrees by each of the iPWR designs by incorporating the passive safety features (i.e., reduce or eliminate the need for active safety systems) discussed above by 1) passively removing decay heat without the use of safety-related emergency AC power, additional water, or operator actions for at least 36 hours, in the case of the CAREM-25 reactor, and up to an unlimited time, in the case of the NuScale reactor, 2) providing for a large heat sink to preclude a loss of cooling water for an extended/indefinite period of time, and 3) using natural circulation, rather than forced circulation, of cooling water during normal plant operations to eliminate transients induced by SBO events (i.e., CAREM-25, SMR-160, NuScale). These passive safety systems provide significant additional time margin than the few hours available in current generation PWRs where the events described above have occurred.

Finally, PWR technology is the primary means of propulsion for nuclear powered submarines and other marine/naval vessels used by various countries throughout the world. While there have been numerous reported core meltdown events and other major mishaps associated with the nuclear reactors used in naval vessels, it is important to note that there are vastly different design features between PWRs used for marine/naval vessel propulsion and PWRs (both current generation and next generation iPWRs) used for power production that make a direct comparison between the two impracticable. The most important distinguishing feature between the two PWR types is that a marine/naval-type reactor must be designed to be physically small so as to fit within the space constraints of a marine/naval vessel. This design requirement necessitates use of a PWR that has a much higher power density (power per unit of space) than that required by land-based PWRs. Furthermore, the power density must be even higher for naval vessels than non-naval marine vessels because of the fast-response power requirements of naval vessels. To minimize space and achieve these higher power densities, 1) the uranium enrichment must be much greater (high-enriched uranium or HEU in naval vessels compared to low-enriched uranium or LEU in iPWRs)<sup>12</sup>, 2) the fuel material is vastly different (uranium metal-zirconium alloy in naval vessels compared to uranium oxide in iPWRs), and 3) active-powered, fast-acting coolant and emergency systems are necessary (precluding the use of passive systems like those used in iPWRs). Principally because of the need to use HEU fuel in SMNRs used in naval vessels, these SMNRs cannot be directly used in NPPs.

---

<sup>12</sup> HEU fuel is defined as having a Uranium-235 (U-235) content greater than or equal to 20% while LEU fuel is defined as having a U-235 content less than 20%. Generally, iPWRs have U-235 content in the fuel of less than about 5%.





## 4.0 Small Heavy Water Reactors (HWRs)

Pressurized heavy water thermal-neutron reactors (PHWRs) have been deployed extensively in Canada and several other countries as the Canadian-developed CANDU (CANadian Deuterium Uranium) reactor. While the electricity generation capacity of the CANDU reactor is typically several hundred MWe, India has extensively developed and deployed PHWRs, which are based on the CANDU reactor design, having capacities less than 300 MWe. In addition, India is developing an advanced heavy water reactor (AHWR) that is different than PHWRs in three key aspects: 1) utilizes thorium/enriched uranium fuel (to take advantage of India's extensive natural thorium resources) rather than natural uranium, 2) utilizes boiling light water as the primary coolant rather than pressurized heavy water so as to use natural circulation of cooling water during all modes of plant operations, and 3) extensively utilizes passive and inherent safety features that significantly reduce the possibility of severe (core damaging) accidents.

It is questionable that either the PHWR or the AHWR can truly be considered “modular” given the large size of certain components that may have to be manufactured at the reactor site (e.g., containment vessel). However, every reactor design, no matter how small, has some amount of on-site construction (such as the foundation and structure containing the reactor) that can't just be manufactured in a factory. Therefore, since both the PHWR and AHWR are considered “small” reactors, and most components could be manufactured in a factory, both are included in this study.

Generic advantages of small heavy water reactors, similar to the iPWRs, are that 1) they can be deployed in regions that have less potential for other types of economical carbon-free electricity, such as wind or solar energy, 2) they can be deployed in regions that have limited electricity transmission (grid) capacity, and 3) they can be configured for co-generation of electricity, steam for district heating, and/or for desalination of water. Disadvantages include 1) the levelized cost of electricity may be somewhat higher than large PHWRs due to economies of scale (although the simpler design of the AHWR may be able to offset this) and 2) the steam generation quality (pressure and temperature) is not suitable for use in many process heat applications generally and for SAGD operation specifically (the temperature and pressure of the steam are less than 315°C and 9 MPa, respectively). Specific advantages of the PHWR and the AHWR include:

- PHWR: Extensive operating history and similarity to the CANDU reactor design that, at a fundamental level, could make licensing easier and faster in Canada (except that the potential proliferation issue identified below may negate this potential advantage);
- AHWR: Potential safety benefits include eliminating LOCAs due to a ruptured pressure tube, very long or even indefinite time periods to respond to loss of offsite power (from use of natural circulation and large water reservoirs for cooling), and reduced potential for transients that trip the reactor offline (because of fewer active components);
- AHWR: Improved public acceptance of nuclear power due to the elimination of or significant reduction in the source term released during an accident, which would support elimination of or significant reduction in the Emergency Planning Zone (EPZ);
- AHWR: Reduced financial risk compared to PHWRs due to simpler design (i.e., elimination of need for redundant safety trains); and

- AHWR: Capable of being used for either baseload or load-following (non-baseload) operation.

Specific disadvantages of the PHWR and the AHWR include:

- PHWR: Heightened proliferation risk with using natural uranium fuel, heavy water, low burnup fuel, and on-line refueling because these can be easily used to optimize the generation of weapons-grade plutonium;
- AHWR: Heightened proliferation risk with using heavy water and on-line refueling, which can be used to optimize the generation of weapons-grade plutonium if the fuel were to be changed to natural uranium fuel; and
- AHWR: Heightened proliferation risk from using  $\text{UO}_2$  enriched to 19.75%  $^{235}\text{U}$  because of its increased attractiveness as a theft target as compared to iPWR fuel using  $\text{UO}_2$  enriched to less than 5%  $^{235}\text{U}$ .

A brief description of each of the heavy water reactor concepts evaluated in this study and their development status is provided below.

## 4.1 Small HWR Concepts

### *AHWR300-LEU by Bhabha Atomic Research Centre (BARC) [India]*

The AHWR300-LEU is a pressure-tube type heavy water moderated, light water cooled reactor having a design electrical/thermal capacity of 304  $\text{MW}_e$ /920  $\text{MW}_{th}$ . Based on the pressurized heavy water reactor (PHWR) technology deployed extensively in India, which is itself based on the CANDU (Canadian Deuterium Uranium) reactor technology deployed extensively in Canada, the core is contained in a large calandria vessel that is vertical rather than horizontal. Each pressure tube holds just one fuel assembly that is long relative to even standard PWR/BWR fuel assemblies, unlike PHWR/CANDU reactors in which each pressure tube holds 12 relatively short fuel assemblies. The fuel is non-standard in that it contains  $\text{UO}_2$  in a mixture with  $\text{ThO}_2$  and the uranium is enriched to 19.75%  $^{235}\text{U}$ . The calandria vessel is filled with heavy water, which acts as both moderator and reflector, and the primary coolant, light water, circulates in the vertical channels (pressure tubes). Similar to a BWR, the cooling water boils as it heats up in the reactor, which provides the motive force for the turbine-generator. Hence, unlike the PHWR/CANDU, this reactor does not have steam generators. Each plant is designed to contain a single reactor module. Figure 4.1-1 provides a conceptual drawing of the AHWR300-LEU reactor.

The reactor core is cooled by the natural circulation of the cooling water during normal plant operation (no reactor coolant pumps needed). Passive safety features allow for the passive removal of decay heat for seven days without safety-related emergency AC power or operator actions. The calandria or reactor core is located underground providing protection against aircraft impact.

No schedule has been announced for the licensing safety review by the Indian regulator. A pre-licensing review of the original AHWR design (using plutonium fuel) has been completed and the AHWR was approved by the regulator in principle. The regulator required testing of various unique design aspects of the AHWR prior to licensing, including passive cooling features and the thorium fuel, and this testing by

BARC is underway. Construction of a demonstration plant is planned to begin in 2016/2017, although no site has apparently been selected yet. Based on this, the AHWR300-LEU is judged to have a TRL of 3-4 and an estimated commercialization time window of 10-15 years.

Additional information about the AHWR300-LEU reactor can be found in the following references: IAEA November 2013, IAEA 2014, Elsevier Ltd. 2011, Elsevier Ltd. October 2013, and SNL 2015.

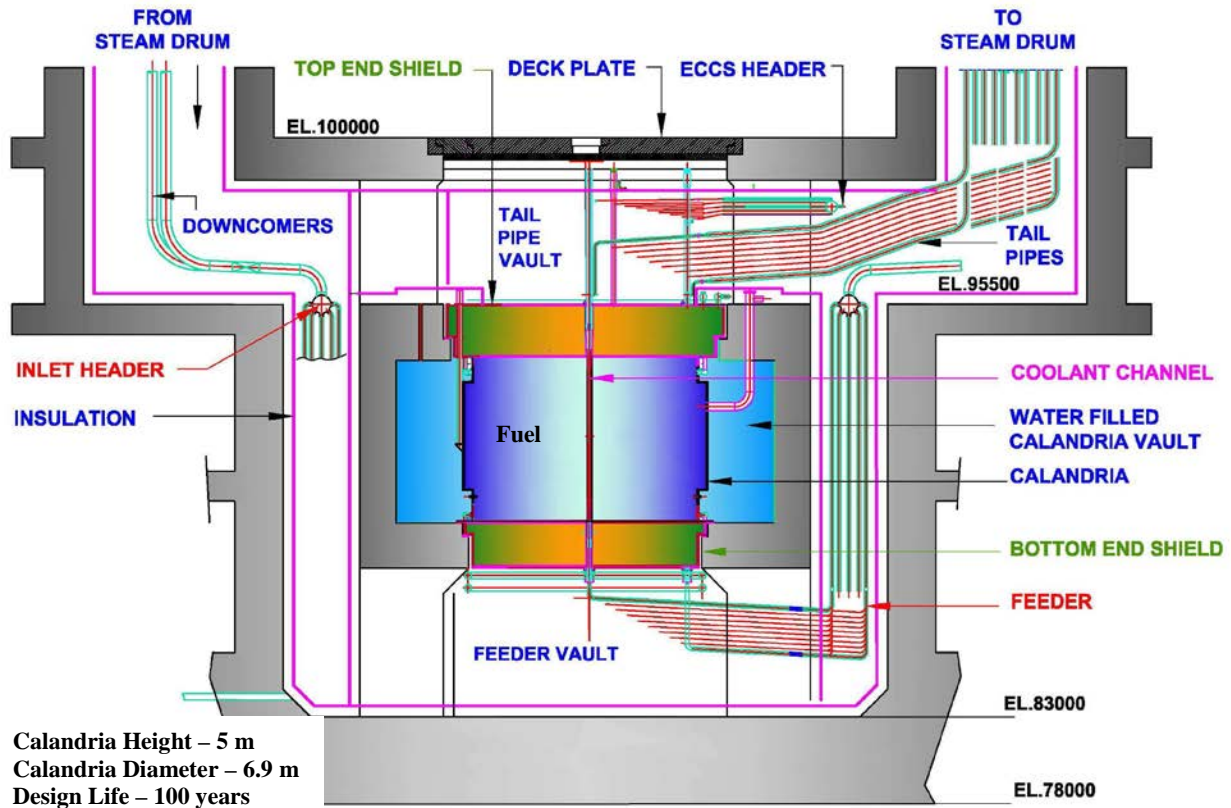

Figure 4-1. Conceptual Drawing of the AHWR300-LEU Reactor

***PHWR220 by Nuclear Power Corporation of India Ltd. (NPCIL) [India]***

The PHWR-220 is a pressure-tube type heavy water moderated and cooled reactor having a design electrical/thermal capacity of 236 MW<sub>e</sub>/755 MW<sub>th</sub>. This pressurized heavy water reactor (PHWR) design has been deployed extensively in India, starting in 1981, which is itself based on the CANDU reactor technology deployed extensively in Canada. The reactor core is contained in a large horizontal calandria vessel containing 306 pressure tubes. Each pressure tube holds 12 relatively short fuel assemblies. The fuel is standard CANDU fuel containing natural UO<sub>2</sub> so enrichment of the uranium is not necessary. The calandria vessel is filled with light water, which provides a secondary cooling source, and the primary coolant and moderator, heavy water, circulates in the pressure tubes. Heat exchangers are used to transfer the hot heavy water to light water in a secondary loop causing it to boil, which provides the motive force for the turbine-generator. Each plant is designed to contain two reactor modules. Figure 4.1-2 provides a conceptual drawing of the PHWR-220 reactor.

The reactor core is cooled by the forced circulation of the cooling water during normal plant operation (primary or reactor coolant pumps are needed). Safe reactor operation relies primarily on active safety features. The calandria or reactor core is located above ground.

A total of 16 similarly-designed/sized units have been licensed for electricity production and are currently in operation in India. While NPCIL has made the PHWR-220 reactor available for export outside of India, there have been no announced sales to-date. Given the extensive operational experience of this reactor type in both India and Canada (although the CANDU reactors are larger), no unique or challenging regulatory issues are envisioned for use in Canada. Based on this, the PHWR-220 reactor is judged to have a TRL of 9-10 since it has been successfully deployed for commercial use.

Additional information about the PHWR-220 reactor can be found in the following references: IAEA April 2011, IAEA July 2011a, IAEA September 2012, and CNS 2014.

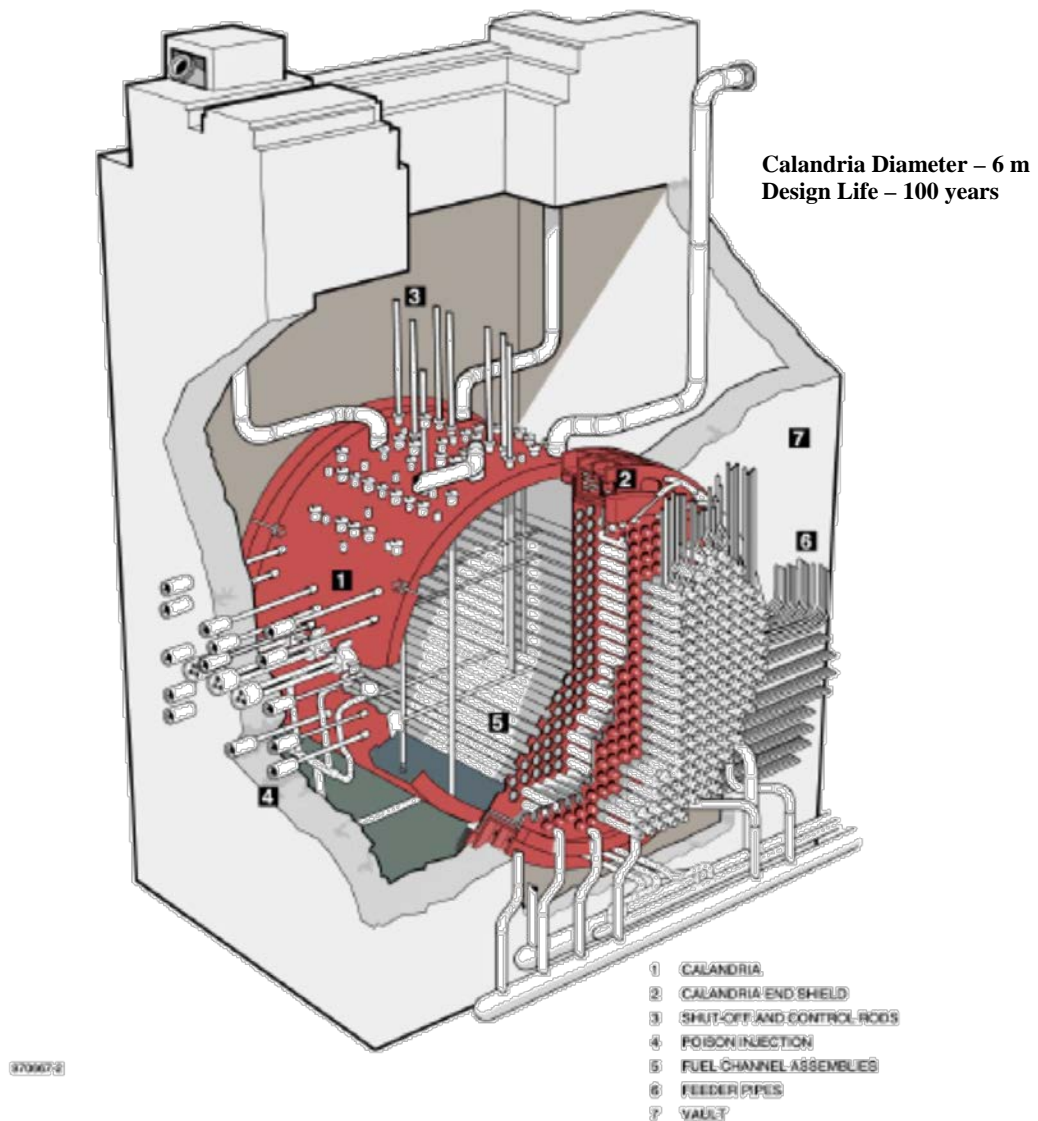

Figure 4-2. Conceptual Drawing of the PHWR-220 Reactor

## 4.2 Operational Experience with Small HWRs

There have been over 50 large ( $>300$  MWe) and small ( $\leq 300$  MWe) PHWRs built and operated around the world, as follows: Canada (22), Argentina (2), Romania (2), Pakistan (1), India (18), China (2), and South Korea (4) (CNSC 2014). While there have been no accidents at any of these reactors that resulted in core damage and consequential release of radioactive materials to the environment, a major accident at the Narora Atomic Power Station Unit 1 (202 MWe) in India occurred on March 31, 1993 that almost resulted in core damage. Classified on the International Nuclear and Radiological Event Scale (INES) Scale as a Level 3 accident, this event involved a major fire in the turbine building that resulted in the total loss of power to the unit for over 17 hours and consequential loss of cooling to the reactor. The fire caused extensive damage to power and control cables and bus ducts that rendered the emergency control room unusable, and heavy smoke ingress into the main control room forced the operators to vacate the control room. To prevent core damage during this long blackout event that rendered emergency core cooling and decay heat removal systems inoperable, the operators injected fire water directly into the secondary side of the steam generators.

Also, while not involving small PHWRs, two serious loss of coolant accidents (LOCAs) occurred at the Pickering Nuclear Generating Station Unit A2 (515 MWe) in Canada. The first was on August 1, 1983 when a pressure tube ruptured during plant operation. The second and more serious accident occurred on December 10, 1994 when a pipe break resulted in a major LOCA that required the use of the Emergency Core Cooling System to prevent a core meltdown. This accident is considered to be Canada's worst nuclear power plant accident.

All of these events occurred at reactors requiring active safety systems to prevent core damage. The passive safety features of the AHWR300-LEU, principally passive removal of decay heat for seven days without safety-related emergency AC power or operator actions, provides significant additional time margin than the few hours available in the PHWRs where the accidents occurred.

Additional information on these major operational events can be found in the following reference: International Journal of Scientific & Engineering Research 2012 and The Standing Senate Committee on Energy, the Environment and Natural Resources, 2001.



## 5.0 Small High-Temperature Gas-Cooled Reactors

A high temperature gas-cooled thermal-neutron reactor (HTGR), of the types considered in this report, is an inherently safe (i.e., no harmful release of radioactive material is possible under any accident conditions) nuclear reactor technology that utilizes helium gas as the coolant and nuclear-grade graphite as the neutron moderator. The reactor and the nuclear heat supply system (NHSS) are generally comprised of three major components: the reactor vessel, the steam generator or heat exchanger vessels, and the cross vessels that routes the helium between the reactor and the steam generators or heat exchangers. When utilizing steam generators, the NHSS supplies energy in the form of steam that can be used for the high efficiency generation of electricity (Indirect Rankine Cycle) and to support a wide range of industrial processes requiring large amounts of process heat in the form of steam. When utilizing heat exchangers, the NHSS supplies energy in the form of high pressure and high temperature helium that can be directly used for the high efficiency generation of electricity (Direct Brayton Cycle) and for the production of hydrogen<sup>13</sup>. This flexibility of providing both electricity and high temperature process heat, in addition to hydrogen production, which can be utilized for a variety of industrial applications as well as for cogeneration, is a potentially significant advantage compared to PWR technology.

There are basically two HTGR design concepts: pebble-bed core and prismatic-block core. Both use tristructural-isotropic (TRISO) fuel that is designed to not crack at very high temperatures. In a pebble-bed reactor, thousands of TRISO fuel particles are dispersed into graphite pebbles. Figure 5-1 provides a schematic of a typical fuel pebble used in a pebble-bed reactor (ORNL 2009). In a prismatic-block reactor, the TRISO fuel particles are fabricated into compacts and placed in a graphite block matrix. Figure 5-2 provides a schematic of a typical prismatic-block fuel assembly, including TRISO fuel particles and fuel compacts (ORNL 2002).

Generic advantages of HTGRs are that 1) they also can be deployed in regions that have less potential for other types of economical carbon-free electricity, such as wind or solar energy and 2) they also can be deployed in regions that have limited electricity transmission (grid) capacity. Specific advantages of the HTGR include:

- Safety benefits of the TRISO fuel, which maintains its integrity (contains most fission products and does not melt) under worst case accident scenarios (ORNL 2014) and allowing for an unlimited time period to respond to loss of offsite power;

---

<sup>13</sup>Three methods have garnered the most attention for the generation of hydrogen using nuclear energy: (1) Sulfur Iodine (SI) process, (2) Hybrid Sulfur Electrolysis (HyS) process, and (3) High Temperature Steam Electrolysis (HTSE) process. All three processes are water-splitting processes and require further development before commercial deployment. The HTSE process was selected as the preferred process for further development by the U.S. Department of Energy (DOE) for the Next Generation Nuclear Plant (NGNP), which is an HTGR. In this process, solid oxide electrolysis cells use heat and electricity from a HTGR to split water and create hydrogen and oxygen. See the following reference for additional information on this selection process: Dominion Engineering, Inc., August 2009, “NGNP Hydrogen Technology Down-Selection Results of the Independent Review Team (IRT) Evaluation,” Report #R-6917-00-01 Revision 0, prepared for Idaho National Laboratory ([https://art.inl.gov/NGNP/NEAC%202010/INL\\_NGNP%20References/R-6917-00-01%20NGNP%20Hydrogen%20Tech%20-%20IRT%20Eval.pdf](https://art.inl.gov/NGNP/NEAC%202010/INL_NGNP%20References/R-6917-00-01%20NGNP%20Hydrogen%20Tech%20-%20IRT%20Eval.pdf)).

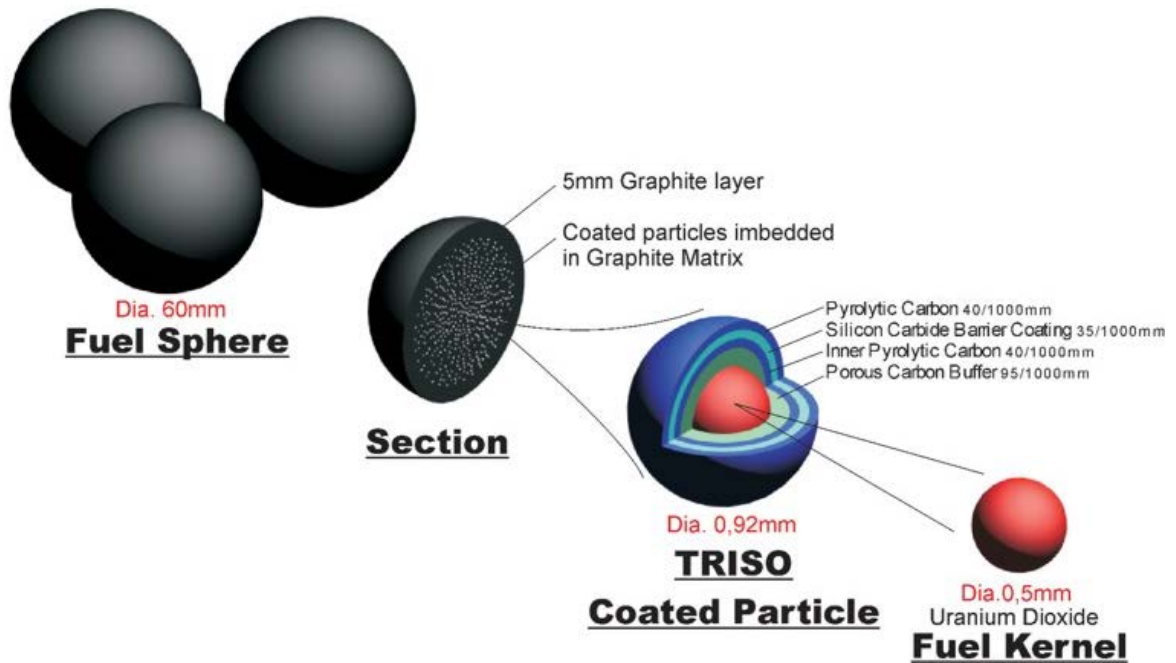

Figure 5-1. Schematic of a Typical TRISO Fuel Pebble

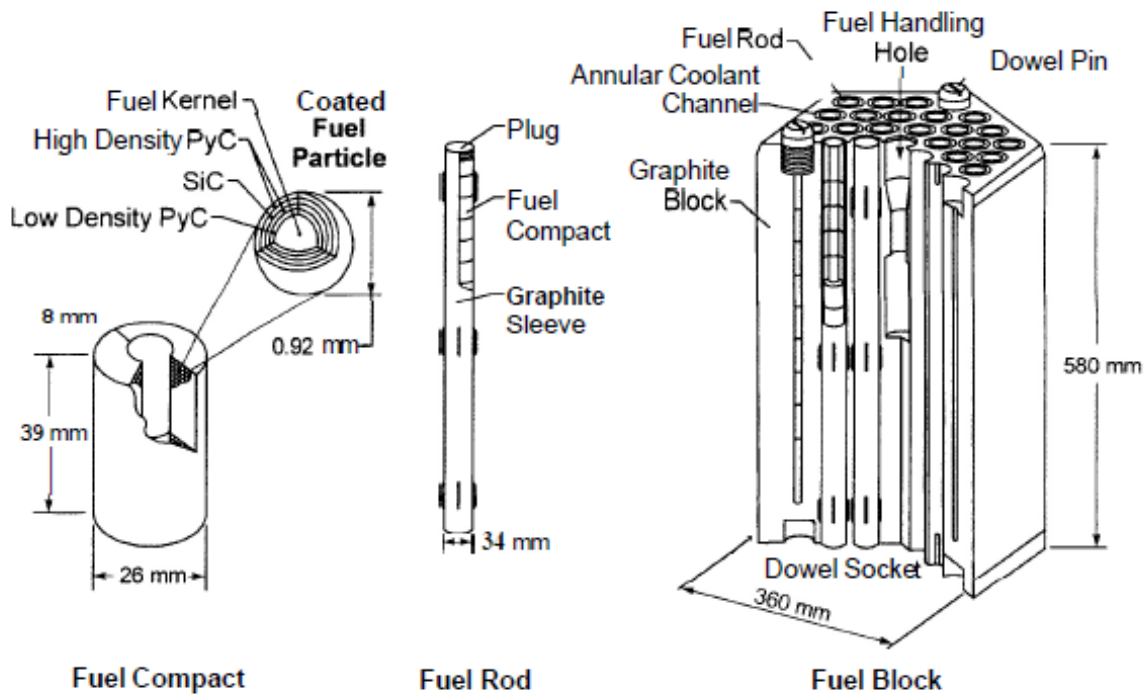

Figure 5-2. Schematic of a Typical Prismatic-block Fuel Assembly



- Low energy density and large heat capacity of the graphite reactor core that will not reach temperatures that jeopardize the integrity of the TRISO fuel (i.e., cannot melt and release large quantities of fission products);
- These benefits eliminate the need for active emergency core cooling systems and, potentially, significantly reduce the size of the emergency planning zone, thus simplifying operations;
- Improved public acceptance of nuclear power due to the elimination of or significant reduction in the source term (i.e., fission products) released during an accident; and
- Can be configured for co-generation of electricity, high temperature process steam (suitable for SAGD operation), steam for district heating, desalination of water, and/or hydrogen generation. While not considered in this report, hydrogen can also be used in Alberta oil sands operations for bitumen upgrading.

The disadvantages of HTGRs include:

- HTGR technology does not have the extensive operational history and experience that exists with light-water reactors, and the limited operational experience with HTGRs is mixed; and
- The levelized cost of electricity may be somewhat higher than for similarly sized iPWRs because the core size (and plant footprint) is larger due to HTGRs having a significantly lower power density and because of the non-standard fuel design (although the elimination of safety systems, reduced EPZ, and other benefits may be able to offset these disadvantages).

A range of different HTGR concepts were selected for review to allow appropriate comparison of the various factors identified in Appendix A. A few of the concepts are clearly at a development stage less than the Technology Readiness Level (TRL) of 5 specified in the SOW. These are included because the concept is either a well-known and much discussed concept in the international nuclear community or has unique design features that may be of interest (i.e., precludes on-site refueling or fuel handling). A brief description of each HTGR evaluated in this study and its development status is provided below.

## 5.1 Small HTGR Concepts

### *GT-HTR300 (Gas Turbine High Temperature Reactor 300 MWe) by Japan Atomic Energy Agency (JAEA) [Japan]*

The GT-HTR300 is a prismatic-block type SMNR having a design electrical/thermal capacity of 280-300 MW<sub>e</sub>/600 MW<sub>th</sub>. The primary circuit consists of the RPV housing the reactor core, a pressure vessel housing the heat exchangers (or recuperator/precooler), and a pressure vessel housing the gas turbine generator. The heat exchangers and gas turbine generator are connected to the RPV via individual concentric cross-vessels or ducts. The primary system is enclosed in the reactor building or concrete shield structure. Each plant is designed to contain up to four reactor modules. Figure 5.1-1 provides a conceptual drawing of the GT-HTR300 reactor system and hydrogen production plant configuration. Figure 5.1-2 provides the heat/energy balance for the GT-HTR300 in an electricity production configuration.

The reactor core is cooled by the forced circulation of helium coolant, which is chemically inert and thus does not present the hydrogen generation potential as with iPWRs. Passive safety features allow for the passive removal of decay heat for an unlimited time period by natural draft air cooling from the outside of the reactor vessel without safety-related emergency AC/DC power, additional coolant, pumps, or operator actions. The primary system including the RPV is located underground.

The design of this reactor is a scaled-up version of the High Temperature Engineering Test Reactor (HTTR), having a thermal capacity of 30 MW<sub>th</sub>, that has been operating in Japan since 1998. Hence, much of the fuel and graphite moderator irradiation testing, and thermal-hydraulic testing of the helium cooling systems, has been completed or is currently being conducted at the HTTR. The HTTR however has been shutdown since the 2011 accident at the Fukushima Daiichi Nuclear Power Plant, with no clear timeline for restart. A demonstration plant that will demonstrate the production of hydrogen is planned for development and commercialization by 2030. Based on the completion of much of the required testing at the HTTR, the GT-HTR300 is judged to have a TRL of 5-6. However, based on the extended shutdown of the HTTR test reactor and unclear schedule for restart, and the likely delay in development of the demonstration plant, the commercialization time window is estimated to be 15-20 years.

Additional information about GT-HTR300 can be found in the following references: IAEA July 2011b, IAEA July 2012a, IAEA 2014, IAEA August 2015c, and IAEA October 2015.

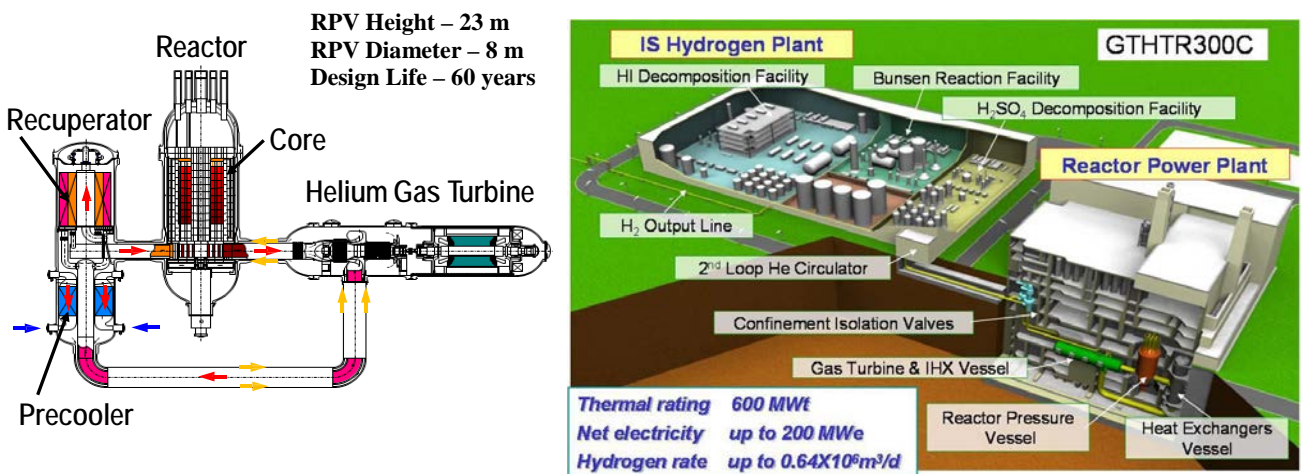

Figure 5.1-1. Conceptual Drawing of the GT-HTR300 Reactor System and Hydrogen Production Plant<sup>14</sup>

<sup>14</sup> The hydrogen production plant depicted utilizes the Sulfur Iodine (SI) process, which has been successfully demonstrated by JAEA at the HTTR.

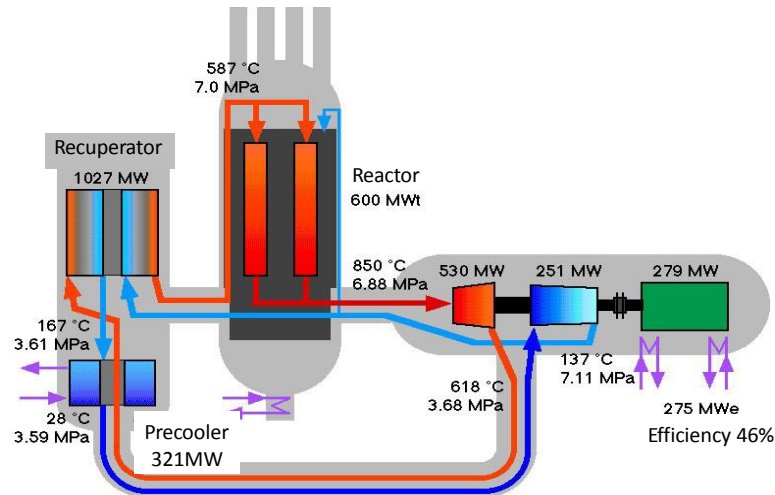

Figure 5.1-2. Heat/Energy Balance for the GT-HTR300 Plant Producing Electricity

### ***GT-MHR (Gas Turbine Modular Helium Reactor) by OKBM Afrikantov [Russian Federation]***

The GT-MHR is prismatic-block type HTGR that is conceptually similar to the GT-HTR300 in many respects, including having a similar design electrical/thermal capacity of 280 MW<sub>e</sub>/600 MW<sub>th</sub>. The primary circuit consists of the RPV and the Power Conversion System. The Power Conversion System, which is a pressure vessel containing the heat exchangers and gas turbine generator, is connected to the RPV via a concentric cross-vessel or duct. The primary system is enclosed within a sealed two-chamber containment (one chamber containing the RPV and the other chamber containing the Primary Conversion System). Both chambers are enclosed in a concrete Reactor Containment Building. Each plant is designed to contain one reactor module, although the number of modules can be expanded depending on the application. Figure 5.1-3 provides a conceptual drawing of the GT-MHR reactor system.

Also like the GT-HTR300, the reactor core is cooled by the forced circulation of helium coolant and the neutron moderator is high-density reactor-grade graphite, which has sufficient heat capacity/heat conductivity to preclude fuel melt accidents. Passive safety features allow for the passive removal of decay heat for an unlimited time period via natural convection to air-cooled panels in the Reactor Cavity Cooling System (and natural draft air cooling towers) without safety-related emergency AC/DC power, additional coolant, pumps, or operator actions. The reactor containment building containing the entire primary system including the RPV is located below ground.

The design of this reactor builds on the experience with prismatic core HTGRs previously licensed and operated in the U.S. (i.e., Fort St. Vrain, Peach Bottom Unit 1). In fact, the development of the reactor concept was a collaborative effort between OKBM Afrikantov and General Atomics (a U.S.-based company that designed the Fort St. Vrain and Peach Bottom power reactors). General Atomics has since backed out of the collaborative effort and OKBM Afrikantov has indicated that they are pursuing further development as an indigenous Russian Federation effort at this time. Further development of this reactor design was suspended in 2013 due to the lack of potential customers, although testing of the power conversion system appears to be on-going. OKBM Afrikantov appears to have no plans for fuel fabrication and irradiation testing, perhaps concluding that TRISO fuel is already sufficiently well-

developed based on testing performed by other international efforts. There is no indication of plans for thermal-hydraulic testing of the reactor cooling systems. It is also noted that there have been no Russian-developed HTGRs that are known to have ever been deployed, experimental or otherwise. The GT-MHR is judged to have a TRL of 5-6 based on the well-developed TRISO fuel and that this reactor concept is an evolutionary design based on the extensive General Atomics experience with past-deployed HTGRs. However, given that further development of the reactor design is suspended indefinitely and that OKBM Afrikantov has no practical experience with HTGRs (likely requiring a prototype or demonstration reactor prior to commercialization), the commercialization time window is estimated to be 15-20 years.

Additional information about GT-MHR can be found in the following references: IAEA 2014 and IAEA February 2015.

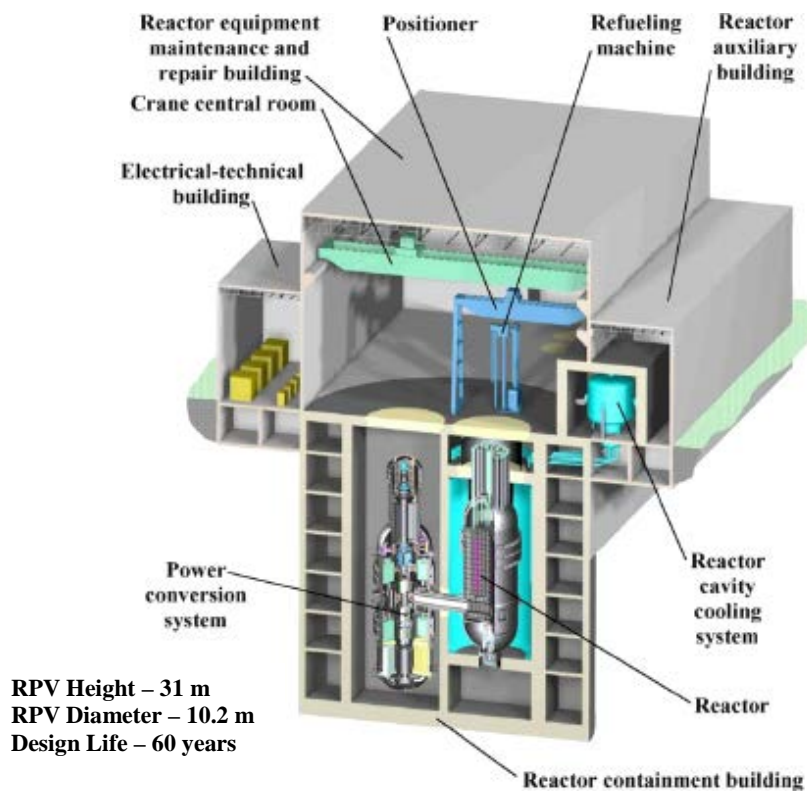

Figure 5.1-3. Conceptual Drawing of the GT-MHR Plant Configuration

***HTR50S by Japan Atomic Energy Agency (JAEA) [Japan]***

The HTR50S is a prismatic-block type HTGR having a design electrical/thermal capacity of 17 MW<sub>e</sub>/50 MW<sub>th</sub>. The primary circuit consists of the RPV housing the reactor core, helium circulator, and, depending on the desired configuration, a pressure vessel housing an intermediate heat exchanger (IHX) and/or a steam generator depending on the application. The heat exchanger or steam generator is connected to the RPV via individual concentric cross-vessels or ducts. The primary system is enclosed in

the reactor building or concrete shield structure. Figure 5.1-4 provides a conceptual drawing of the HTR50S reactor system and plant configuration for process/district heat applications. Figure 5.1-5 provides the heat/energy balance for the HTR50S in a variety of plant configurations for producing electricity, district heat, process heat, and/or hydrogen.

Similar to the other HTGRs described in this report, the reactor core is cooled by the forced circulation of helium coolant and the neutron moderator is high-density reactor-grade graphite. Passive safety features allow for the passive removal of decay heat for an unlimited time period without safety-related emergency AC/DC power, additional coolant, pumps, or operator actions. The portions of the reactor building containing the primary system including the RPV is located below ground.

The design of this reactor is very similar to the HTTR, which has a capacity of 30 MW<sub>th</sub>, and which has been operating in Japan since 1998. In fact, the small size of this reactor and its similarity to HTTR is specifically intended to speed the commercialization of Japan-developed HTGR technology. JAEA claims that this reactor concept is available for commercialization now and that additional technology development is not needed (unless the intended application is hydrogen production, in which case further development of the IHX is required). Based on this (non-hydrogen production applications), the HTR50S is judged to have a TRL of 7-8 and an estimated commercialization time window of 5-10 years.

Additional information about HTR50S can be found in the following references: Elsevier Ltd. June 2013, RAHP 2013, IAEA July 2012b, IAEA October 2015, and Hindawi Publishing Corporation 2013.

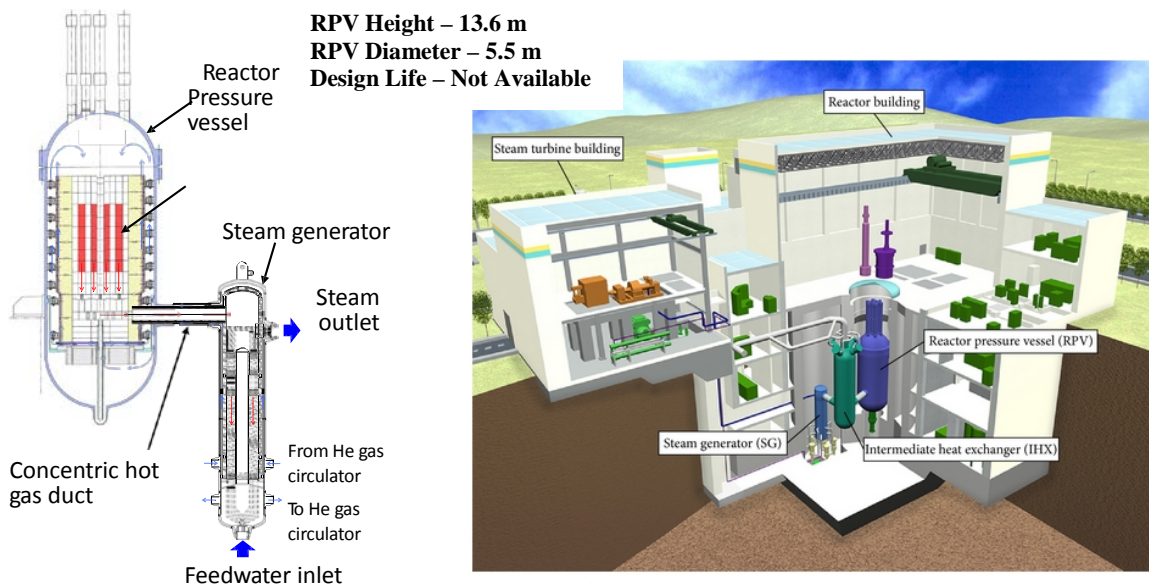

Figure 5.1-4. Conceptual Drawing of HTR50S Reactor System and Plant Configuration



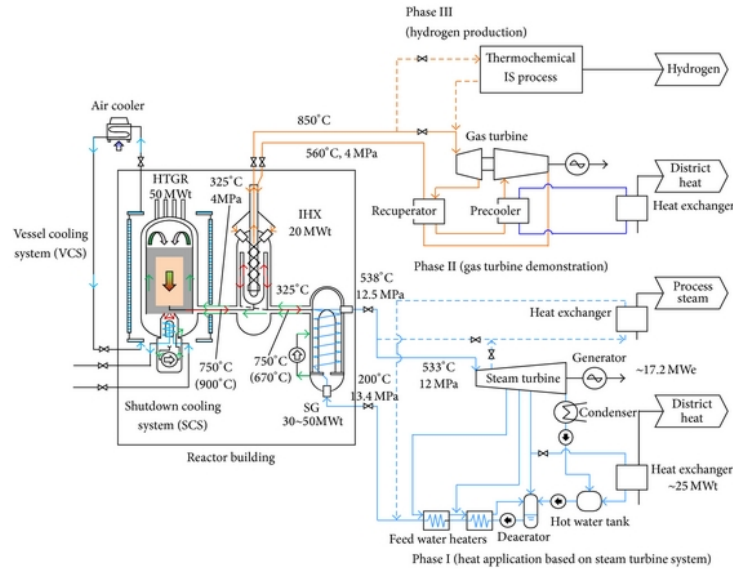

Figure 5.1-5. Heat/Energy Balance for the HTR50S Plant

***HTR-PM by Tsinghua University [People’s Republic of China]***

The HTR-PM is a modular pebble-bed type HTGR having a design electrical/thermal capacity of 105 MW<sub>e</sub>/250 MW<sub>th</sub>. The primary circuit consists of the RPV, the steam generator (SG) pressure vessel and the hot gas duct vessel connecting the two in a side-by-side arrangement. The core is a ceramic cylindrical shell housing the pebble bed, which acts as a reflector, heat insulator and neutron shield. The RPV, SG pressure vessel, and hot gas duct vessel are surrounded by a concrete containment structure. Each plant is designed to contain two reactor modules. Figure 5.1-6 provides a conceptual drawing of the HTR-PM reactor system and plant configuration.

Similar to the other HTGRs discussed in this report, the reactor core is cooled by the forced circulation of helium coolant and the neutron moderator is high-density reactor-grade graphite. Passive safety features allow for the passive removal of decay heat for an unlimited time period without safety-related emergency AC/DC power, additional coolant, pumps, or operator actions. The decay heat is passively removed from the core under any designed accident conditions by natural mechanisms, such as heat conduction or heat radiation, and keeps the maximum fuel temperature sufficiently low so as to contain nearly all of the fission products inside the TRISO coated fuel particles (i.e., no harmful release of radioactive material is possible under any accident conditions). This eliminates the possibility of core melt and large releases of radioactivity into the environment. Consequently there is no need for emergency core cooling system(s) in the design. The reactor building containing the primary system including the RPV is located above ground.

The design of this reactor is very similar to the HTR-10 prototype HTGR, having a thermal capacity of 10 MW<sub>th</sub>, that has been operating in China since 2000. The preliminary safety analysis report (PSAR) was accepted by the Chinese licensing authorities during 2008-2009. The Final SAR (FSAR) assessment is expected in 2016. The first two unit plant is under construction at the Shidaowan site in China's

Shandong province. First concrete was poured in December 2012 and construction is progressing as planned. Operation is expected towards the end of 2017. Based on this, the HTR-PM is judged to have a TRL of 7-8 and an estimated commercialization time window of 5-10 years.

Additional information about HTR-PM can be found in the following references: IAEA July 2011c, IAEA October 2011, IAEA July 2012c, IAEA September 2014, IAEA August 2015c, INL 2014, ORNL 2009, and Waste Management Symposia, Inc. 2000.

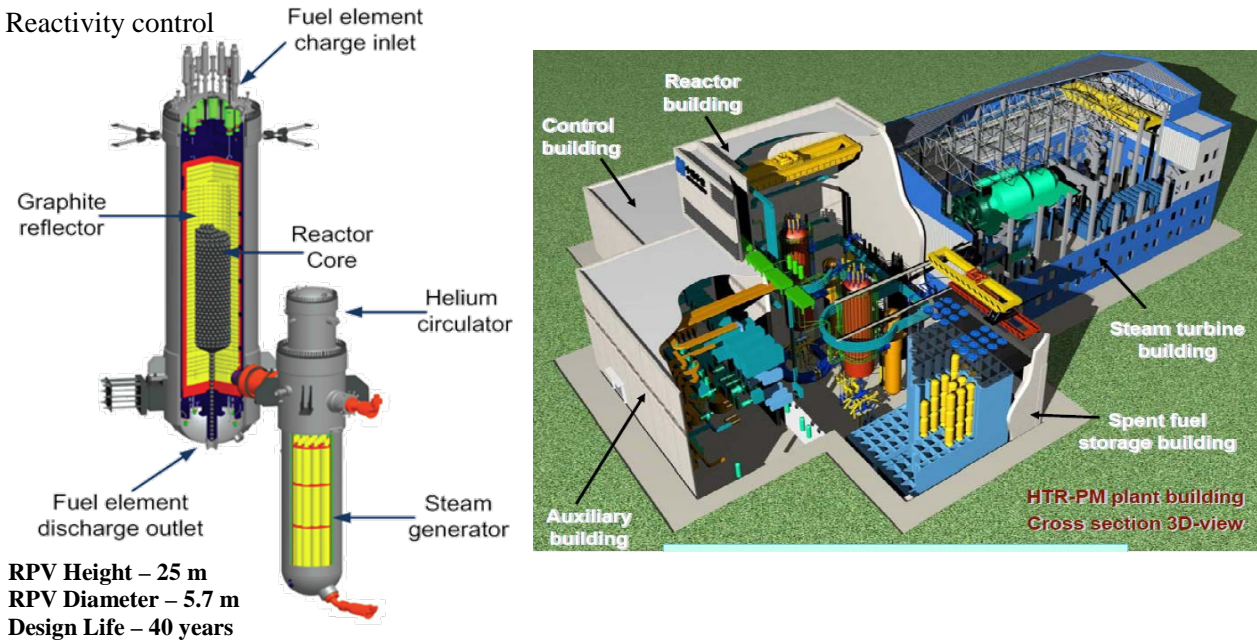

Figure 5.1-6. Conceptual Drawing of HTR-PM Reactor System and 2-Unit Plant Configuration

### ***SC-HTGR (Steam Cycle High-Temperature Gas-Cooled Reactor) by AREVA [USA]***

The SC-HTGR is a modular prismatic block type HTGR having a design electrical/thermal capacity of 272 MW<sub>e</sub>/625 MW<sub>th</sub>. The primary circuit of each reactor module consists of the Reactor Vessel coupled to two Steam Generators, each of which has a dedicated helium coolant Main Circulator. A cross vessel connects each steam generator to the reactor vessel. The reactor vessel contains the reactor core, reactor internals, and control rods. The entire primary circuit is housed within a conventional steel vessel referred to as the Reactor Silo. The reference plant, after the first-of-a-kind built plant, is designed to contain four reactor modules. Figure 5.1-7 provides a conceptual drawing of the SC-HTGR reactor system and silo configuration.

Like the other HTGRs discussed in this report, the reactor core is cooled by the forced circulation of helium coolant and the neutron moderator is high-density reactor-grade graphite. Passive safety features allow for the passive removal of decay heat for an unlimited time period without safety-related

emergency AC/DC power, additional coolant, pumps, or operator actions. The Reactor Silo, containing the entire primary system including the RPV, is located below ground.

The design of this reactor builds on the experience base of past prismatic-block type HTGR plants, principally the Fort St. Vrain and Peach Bottom Unit 1 plants in the U.S. The conceptual design has been completed and the Pre-Licensing Application is being prepared for submission to the NRC. No schedule has been announced for delivery of a design certification application to the NRC. The NGNP (Next Generation Nuclear Plant) Industry Alliance is in the process of selecting a location and determining the funding source for the demonstration plant, which is planned to be operational in the mid-2020s. Based on this, the SC-HTGR is judged to have a TRL of 5-6 and an estimated commercialization time window of 10-15 years.

Additional information about SC-HTGR can be found in the following references: IAEA September 2014, NGNP Industry Alliance Limited 2013, NGNP Industry Alliance Limited June 2015, NGNP Industry Alliance Limited August 2015, NGNP Industry Alliance Limited 2016. AREVA 2014, Nuclear Plant Journal 2014, INL April 2011a, INL 2016, Global Trade Media 2012, and ANS 2014.

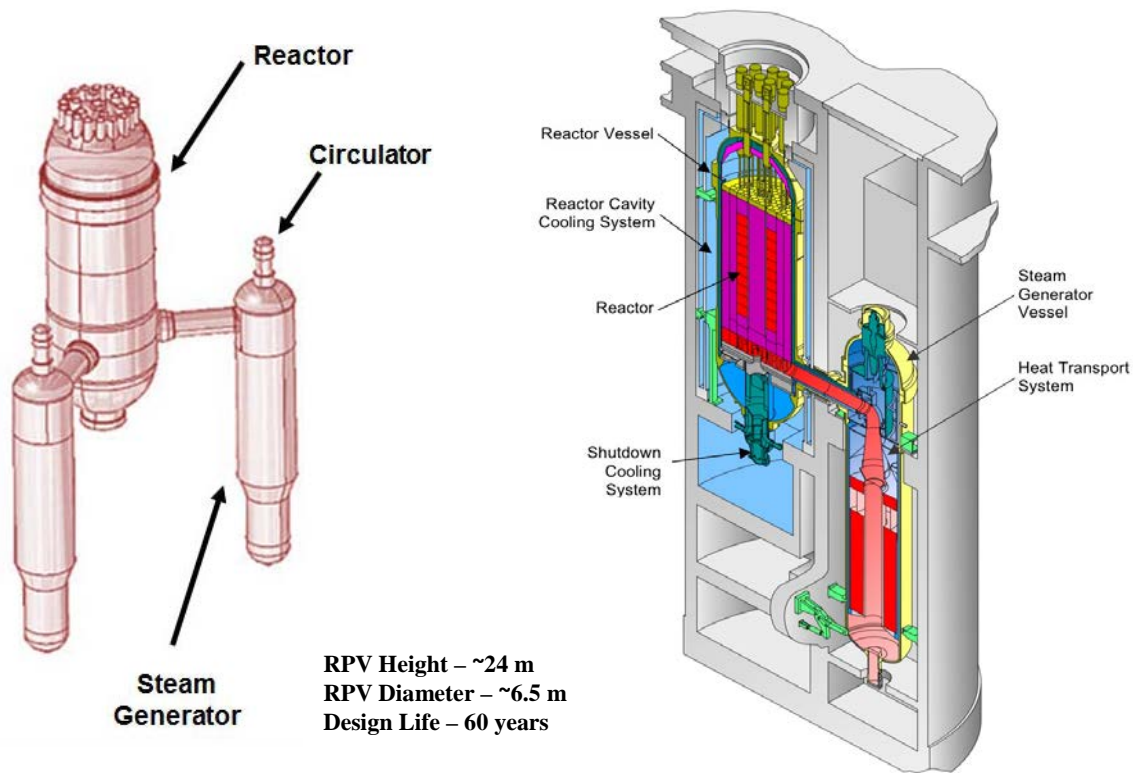

Figure 5.1-7. Conceptual Drawing of SC-HTGR Reactor System and Silo



### *StarCore Co-Generation High Temperature Gas Reactor by StarCore Nuclear [Canada]*

The StarCore is a modular prismatic block type HTGR containing two reactor modules per plant and having a total plant design electrical/thermal capacity of 20 MW<sub>e</sub>/50 MW<sub>th</sub>, with an additional 10 MW<sub>th</sub> dedicated to non-electrical uses (e.g., district heating). There is no publicly-available schematic of the reactor core and primary cooling system, and PNNL is not aware of any publicly-available information on this reactor design other than the high-level description provided here. The primary system is described as being composed of the RPV containing the reactor core, control rods, the first stage Energy Transfer System (ETS-1) that uses helium gas for cooling the reactor, and the first Intermediate Heat Exchanger (IHX-1). The reactor is described as being contained in a modified fuel shipment container that, after transportation from the factory to the plant site, is installed in a steel canister silo that is contained within a double-walled higher performance concrete silo.

Similar to the other HTGRs discussed in this report, the reactor core is cooled by the forced circulation of helium coolant and the neutron moderator is high-density reactor-grade graphite. Passive safety features allow for the passive removal of decay heat for an unlimited time period without safety-related emergency AC/DC power, additional coolant, pumps, or operator actions. The reactor is installed 57 meters underground. A unique aspect of the reactor concept is that the reactor/reactor core is described as being shipped to the site in a single shipment container, installed as described above in a concrete silo, and is removed every 5 years to the reactor vendor site for refueling and/or decommissioning (hence, no on-site operators specialized in refueling operations are required and minimal radiological decommissioning activities would be expected). Another unique aspect of this reactor concept is that reactor operations are described as being monitored remotely from the reactor vendor's plant and so on-site nuclear operators are not necessary (although some monitoring personnel are expected to be located at the reactor site). Personnel needed to operate the non-nuclear balance-of-plant (BOP), including thermal/electric plants, will be located at the reactor site. Also, because of the inherent/passive safety features of the reactor, another feature of this reactor concept is that the reactor site will be publicly-accessible with no overt security fences or guards.

No schedule has been announced for submission of the design certification application to the Canadian regulator, and there have been no announcements of any significant funding or funding partners. Furthermore, there has been no published schedule for the performance of component/fuel testing, although StarCore may be relying on previous experience with TRISO fuel. Finally, PNNL believes certain aspects of the concept pose difficult technical/licensing challenges for implementation by 2030: (1) licensing the reactor vessel as a transportation container/package for the fuel/used fuel, (2) remote monitoring and operation of the reactor, (3) away-from-reactor centralized storage of the used fuel, and (4) publicly-accessible reactor site with no overt security features. Based on this, the StarCore is judged to have a TRL of 1-2 and an estimated commercialization time window of 15-20 years.

Additional information about StarCore can be found in the following references: StarCore Nuclear 2016.

### *Xe-100 by X-energy LLC [USA]*

The Xe-100 is a modular pebble-bed type HTGR, conceptually similar to the HTR-PM, having a design electrical/thermal capacity of 50 MW<sub>e</sub>/125 MW<sub>th</sub>. The primary circuit consists of the RPV, control rods, the steam generator, and the hot gas duct vessel connecting the RPV and steam generator in a side-by-side arrangement. The core is a ceramic cylindrical shell housing the pebble bed, which acts as a reflector, heat insulator and neutron shield. The RPV, control rods, SG pressure vessel, and hot gas duct vessel are surrounded by a concrete structure. Each plant is designed to contain two to eight reactor modules. Figure 5.1-8 provides a conceptual drawing of the Xe-100 reactor system and four-unit plant configuration.

Similar to the other HTGRs discussed in this report, the reactor core is cooled by the forced circulation of helium coolant and the neutron moderator is high-density reactor-grade graphite. Passive safety features allow for the passive removal of decay heat for an unlimited time period without safety-related emergency AC/DC power, additional coolant, pumps, or operator actions. The reactor core (fuel) cannot be overheated to unallowable temperatures, therefore the core can never melt (which eliminates the potential for large releases of fission products). The reactor building containing the primary system, including the RPV, is partially located below ground.

The design of this reactor builds on the experience base with pebble-bed core HTGRs previously licensed and operated in the Germany (i.e., THTR, AVR) and the fuel fabrication and irradiation testing conducted under the auspices of the Next Generation Nuclear Plant (NGNP) initiative in the U.S.

Component/system testing remains to be completed, but is planned following X-energy LLC securing \$53 million in funding from the U.S. Department of Energy (DOE) in 2016. Furthermore, while there is no announced schedule for submission of a design certification application to the U.S., the \$53 million in DOE funding with supplemental private funding will be used to develop the conceptual design with a planned deployment in the mid-2020s. Based on this, the Xe-100 is judged to have a TRL of 4-5 and an estimated commercialization time window of 10-15 years.

Additional information about HTR-PM can be found in the following references: IAEA September 2014, X-energy LLC 2014, X-energy LLC 2015.

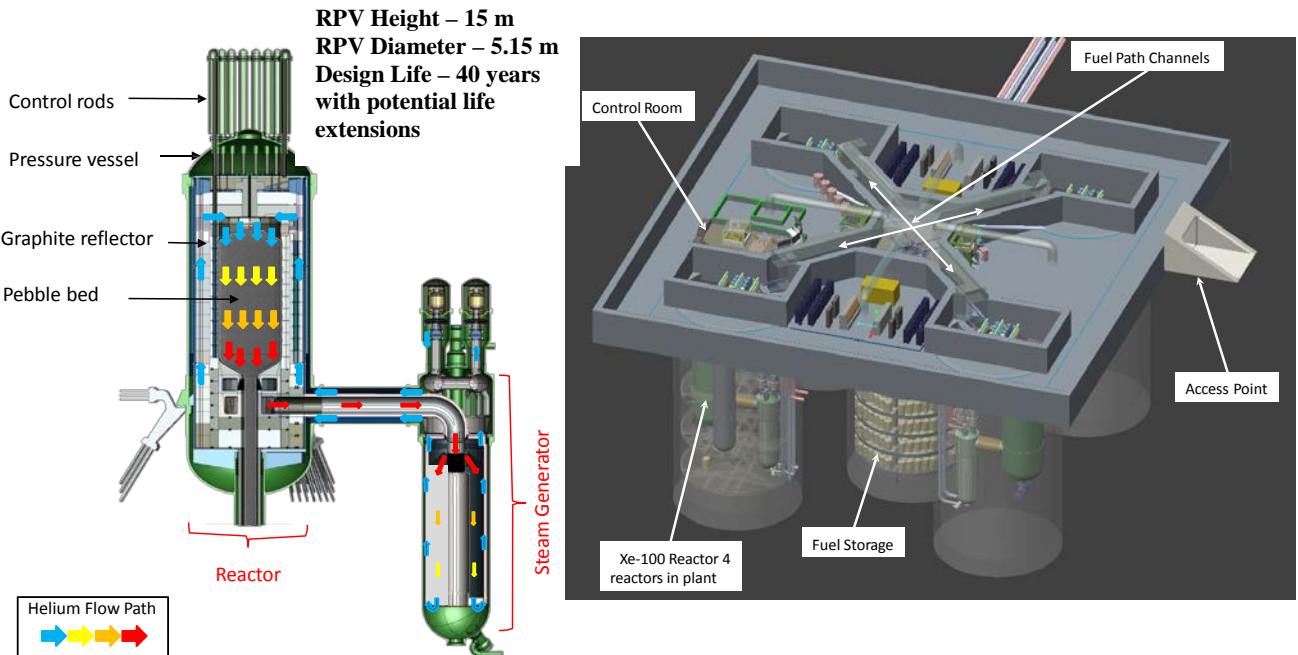

Figure 5.1-8. Conceptual Drawing of Xe-100 Reactor System and 4-Unit Plant Configuration

## 5.2 Operational Experience with Small HTGRs

Only three pebble-bed type HTGRs have been built and operated: 1) the experimental AVR reactor (15 MW<sub>e</sub>) in Germany (1966 to 1988), 2) the prototype power generation THTR-300 (300 MW<sub>e</sub>) in Germany (1985 to 1989), and 3) the prototype HTR-10 (10 MW<sub>th</sub>) reactor in China (2000 to present). None of these HTGRs experienced a significant safety event during its operation. The AVR and THTR-300 have experienced relatively minor events that were rated Level 3 (“serious” incident) on the INES Scale.

Specifically, both the AVR-10 and THTR-300 experienced fuel failures that contaminated the containment structures. Also, the THTR-300 experienced a minor incident in 1986 (several months after startup) that resulted in a small release of radioactivity, caused by a human error during removal of a fuel pebble that got stuck during refueling operations. The handling of this minor incident, coming on the heels of the Chernobyl accident, severely damaged the credibility of the HTGR community in Germany and is often cited as one of the major reasons both HTGRs were permanently shutdown soon thereafter. There have been no known incidents of significance with the operation of the HTR-10 reactor.

The only prismatic-block type HGTRs to operate commercially were in the U.S.: Fort St. Vrain (330 MW<sub>e</sub>) and Peach Bottom Unit 1 (40 MW<sub>e</sub>)<sup>15</sup>. Neither experienced a serious or severe accident, although both experienced significant operational issues.

<sup>15</sup>Other prismatic-block type HTGRs that have been built and operated are the Dragon reactor (20 MW<sub>th</sub>) in the United Kingdom (shutdown in 1975 and in the process of being decommissioned) and the HTR reactor (30 MW<sub>th</sub>) in Japan (still operating). These HTGRs are research and test reactors.

Peach Bottom Unit 1 was an HTGR demonstration plant that operated from 1966 to 1974. This HTGR only operated for 2 core loads. The first core operated only about half of its design life due to failure of 90 fuel elements caused by rupture of the fuel particle coatings. Core 2 used an improved fuel particle design (BISO fuel that was the precursor to TRISO fuel) and was able to operate its full design life. The plant owner decided to shutdown the plant after Core 2 reached the end of its life because the reactor was considered too small to be commercially viable.

The Fort St. Vrain HTGR operated from 1979 to 1989. Like all HTGRs that utilize TRISO fuel, the Fort St. Vrain HTGR precluded the possibility of major core damage or radioactive releases in such a quantity that could seriously threaten public safety. As a result, the Nuclear Regulatory Commission allowed operation with much smaller safety zones compared to LWR designs. It was also notable that plant personnel received negligible radiation exposure during the course of operations. However, many operational issues occurred early in the operational experience of the Fort St. Vrain HTGR. Three major categories of problems were experienced at Fort St. Vrain:

- 1) Issues with water/moisture ingress into the reactor/primary cooling system and resultant material swelling/corrosion. The reactor/primary system of HTGRs are designed to remove moisture from the coolant (i.e., helium for the all of the HGTRs evaluated in the report) to prevent operational and safety issues. Specifically, water ingress during reactor operation can result in positive reactivity insertion, swelling/corrosion of the graphite moderator and other components, preventing/obstructing operation of systems/components, and increases in primary system pressure. Significant water ingress, such as from a steam generator tube rupture, was not the issue at Fort St. Vrain. Rather, water ingress occurred as a result of inadvertent injection and from ingress through materials that were water-lubricated/cooled (e.g., helium circulator bearings).
- 2) Issues with instrumentation and control systems. Instrumentation and controls events were distributed among four general areas: 1) inoperable instruments that were out of calibration or had drifted from their correct set points, 2) instruments that were moved, disturbed, or otherwise subjected to physical motion that produced an erroneous or false signal from the instrument, 3) instruments that failed, sent a false signal, or tripped because of a short between contacts or because the instrument had dirty contacts, and 4) instrument “noise” or a spike on an instrument’s output signal.
- 3) Issues with auxiliary systems. Several of these events were related to inoperable snubbers on auxiliary piping, and several of the events reported failure associated with a single valve. Another event involved the failure of a joint in the circulating water system, resulting in flooding in a pump room. Several other events were randomly distributed among various types of components. For example, a compressor malfunctioned in the helium purification system and charred and burned cables on several components of support systems to the helium circulators. Examples of these support systems include the circulator cold reheat drain valve, bottom head cooling system valves, and drain valves for the helium moisture separator. Several other occurrences involved fire seal penetrations or fire barriers problems. However, events associated with a whole-system problem were the most numerous. For instance, one of the subjects examined was the “frequency of the unavailability of the emergency feed water supply header to the helium circulator water turbine drives.” In essence, the safe shutdown analysis performed by the licensee depended on the emergency firewater system to provide adequate decay heat removal

following a shutdown; however, the system as configured may have been unable to perform its intended safety function.

Although these issues were never a threat to the facility or to public safety, considerable stress was placed upon the personnel, equipment, and facilities and made continued operation uneconomical. While most of the past issues had been resolved at considerable expense and the plant was beginning to perform at a commercially viable level, the owner permanently shut it down after only 10 years of sporadic operation after hairline cracks were discovered in the main steam ring header.

The small HTGRs discussed in the previous section have, in many respects, been expressly designed to preclude similar issues. Specific examples: 1) the new pebble-bed reactor designs have significantly simplified the pebble fuel refueling operations to minimize the possibility of fuel pebbles from getting stuck during refueling operations, 2) high-integrity TRISO fuel is used in all of the small HTGR design concepts to minimize fuel failures, and 3) design improvements have been made to the helium circulators by switching to magnetic bearings from water bearings to prevent water infiltration and corrosion in the helium cooling system.

Additional information on the operational experience with these HTGRs can be found in the following reference: INL 2010 and PNNL 2011.



## 6.0 Molten Salt Reactors

Molten salt thermal-neutron reactors (MSRs) use molten fluoride salts for the reactor coolant and graphite as the neutron moderator. The fuel is typically a molten mixture of the lithium and beryllium fluoride salt coolant with low-enriched uranium fluorides dissolved in the mixture, although solid fuel concepts are being developed. Just three small research MSRs located at the Oak Ridge National Laboratory (ORNL) in Tennessee (USA) have ever been built and operated (in the 1960s), the largest of these being the 7.4 MW<sub>th</sub> Molten Salt Reactor Experiment (MSRE). All three of these utilized a coolant composed of molten fluoride salts with uranium tetrafluoride fuel dissolved in the coolant. However, there is a recognition in the MSR community that molten salt fuel is further from commercialization than solid fuel designs, and so solid fuel design concepts (generally utilizing the TRISO-type fuel previously discussed for HTGRs) are also being pursued for interim deployment.

MSRs have a significant inherent safety feature in that they are designed to automatically shutdown without operator intervention when the temperature of the fuel salt increases beyond design limit (i.e., MSRs have large negative temperature and void coefficients<sup>16</sup>). Other safety advantages include 1) a primary system that operates near atmospheric pressure (i.e., is not pressurized), so a large containment as required for PWRs is not necessary, 2) passive removal of decay heat because of high volumetric expansion with temperature (again, natural circulation without operator intervention), 3) in the case of molten salt fuel, in some designs, fission products are constantly being removed from the salt, via continuous processing of the circulating molten fuel salt, thereby significantly reducing decay heat generation and the amount available for release in the event of an accident, and 4) in the case of solid fuel, TRISO fuel maintains its integrity (contains fission products and does not melt) under worst case accident scenarios and indefinite time periods to respond to loss of offsite power. Disadvantages include 1) the relatively high melting point of the salts increases the complexity of solid fuel refueling operations as the salt must continue to be heated to prevent solidification and 2) some salt elements (e.g., beryllium) are toxic which presents safety challenges.

Other generic advantages of small MSRs, as discussed with other SMNR concepts, are that 1) they can be deployed in regions that have less potential for other types of economical carbon-free electricity, such as wind or solar energy, 2) they can be deployed in regions that have limited electricity transmission (grid) capacity, and 3) can be configured for co-generation of electricity, high temperature process steam (suitable for SAGD operation), steam for district heating, and desalination of water. A disadvantage of small MSRs is a potentially higher levelized cost of electricity because of the on-site salt processing operations and because of the non-standard fuel design (although the elimination of safety systems, reduced EPZ, and other benefits may be able to offset these disadvantages). In addition, because of the lack of development of MSR concepts (e.g., testing and operational data), and very little operational history and experience, significant development work remains before MSRs are ready for commercial deployment, including development and validation of salt handling processes, salt compatibility with

---

<sup>16</sup> Temperature coefficient of reactivity: a measure of how much the reactivity or power level of the reactor changes as the temperature of the fuel and/or coolant/moderator changes. A negative fuel temperature coefficient of reactivity means the reactivity or power level of the reactor decreases as the temperature of the fuel increases (such as due to a loss of decay heat removal capability), and vice-versa. Void coefficient of reactivity: a measure of how much the reactivity of a nuclear reactor changes as voids (i.e., bubbles) form in the reactor moderator or coolant due to boiling or loss of coolant. A negative void coefficient means the reactivity decreases as the void content inside the coolant/moderator increases, and vice-versa.

component materials under operating conditions, and instrumentation and inspection techniques for molten salt components (INL April 2011b).

MSRs are Generation IV<sup>17</sup> reactors that are behind other advanced reactor concepts in their stage of design and technology development. Consequently, MSRs are challenged to be commercially deployable by the year 2030, which is the screening criteria for further consideration of an SMNR concept for this evaluation. Three of the most promising MSR concepts are further considered. While the planned deployment dates for two of these concepts meet the 2030 criteria, the author is highly skeptical of these claims given their current state of development. A brief description of each of the three MSR concepts evaluated in this study and its development status is provided below.

## 6.1 Small MSR Concepts

### *IMSR (Integral Molten Salt Reactor) by Terrestrial Energy [Canada]*

The IMSR is an SMNR that utilizes molten salt fuel and has three possible design electrical/thermal capacities: smallest - 32.5 MW<sub>e</sub>/80 MW<sub>th</sub>, medium - 141 MW<sub>e</sub>/300 MW<sub>th</sub>, largest - 291 MW<sub>e</sub>/600 MW<sub>th</sub>. The sealed reactor vessel (RV) contains the reactor core, first stage heat exchangers, and control rod. The liquid carrier salt (with fuel) pumps and the solid buffer salt are located outside of the reactor vessel. The sealed reactor vessel, pumps, and solid buffer salt are all contained within an outer containment shell (steel liner) referred to as the IMSR unit or Core-Unit. The IMSR unit is enclosed within a concrete containment shell. Figure 6.1-1 provides a conceptual drawing of the IMSR reactor system and plant configuration.

The reactor core is UF<sub>4</sub> fuel that is dissolved within a liquid carrier salt coolant<sup>18</sup>. The forced circulation of the liquid fuel salt is via pumps mounted on top of the reactor vessel. Unlike steam, fluoride salts dissolve poorly in water and so water ingress will not produce hydrogen, which is a potential safety issue with iPWRs. Passive safety features allow for the passive removal of decay heat for a long time period by convective circulation of the molten salt without safety-related emergency AC/DC power, additional coolant, pumps, or operator actions. The IMSR unit is located below ground.

Few standard nuclear-trained operators, including senior reactor operators (SROs), would be required based on the design concept of no on-site refueling and no treatment of the coolant during reactor operations (if the sealed Core-Unit performs as specified (i.e., no leaks)). The used fuel is sealed in Core-

---

<sup>17</sup> Generation IV nuclear reactors are nuclear reactor concepts considered to be revolutionary designs that require significant research and development before being deployed commercially. With the exception of sodium fast reactors (see Section 2.5), these concepts are generally not expected to be available for commercial construction prior to 2030. Generation I nuclear reactors are the first nuclear reactors to be deployed commercially, in the 1950s and 1960s, and were the pre-cursors to most commercial reactors currently operating around the world. Generation II nuclear reactors are the class of nuclear reactors that are generally in commercial operation throughout the world today, including PWRs, BWRs, and CANDUs. Generation III and III+ nuclear reactors are advanced LWRs and evolutionary LWRs that are currently being deployed (e.g., EPR, AP1000) and are intended to provide improved safety and economics over Generation II nuclear reactors. See Reference OECD 2014 for additional information on Generation IV nuclear reactors.

<sup>18</sup> The specific carrier salt has not yet been selected. Terrestrial Energy has indicated that fluoride and chloride salts are being considered.



Units that are swapped out every seven years (but are stored on-site), eliminating the need for trained refueling operators.

The design of this reactor incorporates aspects of the Denatured Molten Salt Reactor (DMSR) design developed by ORNL in the early 1980s and the Small Modular Advanced High Temperature Reactor (SmAHTR) design developed by ORNL in 2010, both of which utilize experience with the MSRE that operated in the 1960s. The pre-conceptual design of the IMSR was completed in 2015 and the conceptual design is planned to be completed in 2017. No specific schedule has been announced for submission of the design certification application to the Canadian regulator, although a pre-licensing design review with the Canadian Nuclear Safety Commission (CNSC) was initiated in early 2016. Construction of a demonstration unit and commercialization is planned for the mid-2020s. The Canadian Federal Government awarded Terrestrial Energy CAD\$5.7 million in March 2016 to support pre-commercial activities, including construction of an electrically-heated non-nuclear mock-up. It is unknown how much additional funds Terrestrial Energy has raised from undisclosed investors. Terrestrial Energy has applied for a loan guarantee with the U.S. Department of Energy (DOE) of between \$800 million and \$1.2 billion to support financing of a project to license, construct, and commission an IMSR in the U.S., with INL identified as the lead candidate site. DOE has completed the evaluation of Part I of the application and has invited Terrestrial Energy to submit Part II of the application. There has been no published schedule for the performance of component/fuel/molten salt testing, although Terrestrial Energy may be relying on previous experience with the MSRE. However, as discussed previously, given the lack of operational experience with MSRs, it is likely that significant development work remains before MSRs are ready for commercial deployment. Based on this, the IMSR is judged to have a TRL of 3-4 and an estimated commercialization time window of 15-20 years.

Additional information about GT-HTR300 can be found in the following references: ANS 2014b, Terrestrial Energy March 2015, Terrestrial Energy October 2015, Terrestrial Energy March 2016, MIT January 2016, and World Nuclear News (WNN) September 2016.

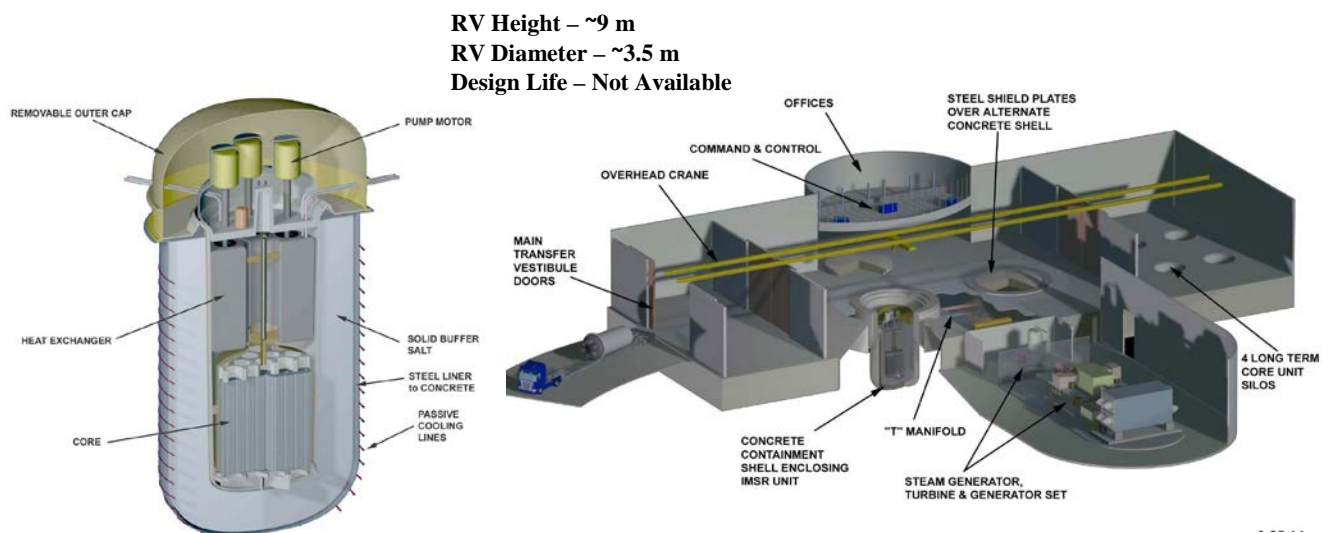

Figure 6.1-1. Conceptual Drawing of the IMSR System and Plant Configuration

***TMSR-SF (Solid-Fuel Thorium Molten Salt Reactor) by Shanghai Institute of Applied Physics (SINAP) [People's Republic of China]***

The TMSR-SF is a planned demonstration reactor that is currently expected to utilize solid fuel (TRISO pebbles), fluoride salts as the coolant (FLiBe<sup>19</sup>), and graphite as the neutron moderator. The plant design electrical/thermal capacity is 45 MW<sub>e</sub>/100 MW<sub>th</sub>. The design of this reactor is still in the pre-conceptual design phase and so little more is currently known about the design of this planned reactor. Construction of an experimental reactor, the TMSR-SF1 (10 MW<sub>th</sub>), that will provide data to advance the development of the detailed design of the TMSR-SF, is planned to be started in 2017 and to be completed in 2020. The subsequent TMSR-SF demonstration reactor is then expected to be constructed by the mid-2020s, with commercial deployment by 2030. While this is an extremely ambitious schedule, the design is being informed via a collaborative agreement between SINAP and ORNL, and it is rumored that the TMSR-SF1 design will essentially mirror that of the MSRE in order to accelerate its design and construction. Based on this, the TMSR-SF is judged to have a TRL of 3-4 and an estimated commercialization time window of 15-20 years. Figure 6.1-2 provides a conceptual drawing of the TMSR-SF1 reactor system.

Additional information about TMSR-SF can be found in the following references: SINAP 2015a, SINAP 2015b, CAS TMSR Center of Excellence 2015, and TMSR Center of CAS 2013.

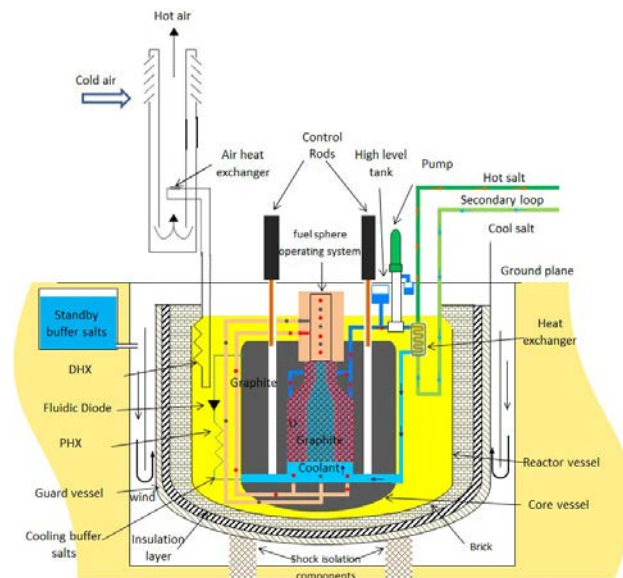

Figure 6.1-2. Conceptual Drawing of the TMSR-SF1 Reactor

***TMSR-LF (Liquid-Fuel Thorium Molten Salt Reactor) by Shanghai Institute of Applied Physics (SINAP) [People's Republic of China]***

The TMSR-LF is a planned demonstration reactor that is currently expected to utilize molten salt fuel. While even a conceptual description is not yet developed, and so little more is currently known about the design of this planned reactor, it is expected that the design will take full advantage of the MSRE experience to accelerate development and so the fuel is expected to be UF<sub>4</sub> dissolved within a liquid

<sup>19</sup> FLiBe is a molten fluoride salt that is a mixture of lithium fluoride (LiF) and beryllium fluoride (BeF<sub>2</sub>).

carrier salt coolant that is a mixture of fluoride salts (FLiBe). The neutron moderator is expected to be graphite. Construction of a test reactor, the TMSR-LF1 (2 MW<sub>th</sub>), that will provide data to advance the development of the conceptual design of the TMSR-LF, is planned to be started in 2017 and to be completed in 2020. Construction of a subsequent experimental reactor, the TMSR-LF2 (10 MW<sub>th</sub>), is planned to be constructed between 2021 and 2025. The subsequent TMSR-LF demonstration reactor is then expected to be constructed by the mid-2030s, with commercial deployment sometime after that. As with the TMSR-SF, the design is being informed via a collaborative agreement between SINAP and ORNL. Based on this, the TMSR-LF is judged to have a TRL of 2-3 and an estimated commercialization time window of 20+ years.

Additional information about TMSR-LF can be found in the following references: SINAP 2015a, SINAP 2015b, CAS TMSR Center of Excellence 2015, and TMSR Center of CAS 2013.

## **6.2 Operational Experience with MSRs**

No power demonstration MSRs have ever been built and operated. However, three small experimental MSRs were built/operated in the 1950s/1960s at ORNL in the USA: 1) the Aircraft Research Experiment (ARE), 2.5 MW<sub>th</sub>, 2) the Pratt and Whitney Aircraft Reactor-1 (PWAR-1), zero power reactor, and 3) the Molten Salt Reactor Experiment (MSRE), 7.4 MW<sub>th</sub>. No accidents or operational events of significance have been reported for any of these experimental reactors.



## 7.0 Fast Reactors

Fast neutron reactors differ from the thermal neutron reactors discussed in the previous sections in that they can generate more fuel than they consume and they more efficiently utilize the intrinsic energy of the fuel. The potential direct benefit of these inherent features are 1) more efficient utilization of the limited fuel source, which extends the availability of the known uranium (and thorium) reserves far into the future and 2) reduced generation of high-level and long-lived radioactive waste requiring isolation for thousands of years. By improving the utilization of natural resources and reducing the amount and radiotoxicity of radioactive wastes, fast reactors offer significant benefits in making nuclear energy production more sustainable.

There are basically four types of fast reactor concepts: 1) the sodium-cooled fast reactor (SFR), 2) the heavy liquid metal-cooled (HLMC) fast reactor 3) the gas-cooled fast reactor (GFR), and 4) the molten salt fast reactor (MSFR). Of the four, the SFR has the most experience base, with several prototype and power-producing reactors having been built and operated over the last few decades in several different countries with mixed success.

The SFR utilizes liquid sodium metal as the reactor core coolant and has the following important safety features: 1) high thermal conductivity properties that remove heat rapidly from the fuel, thus providing long grace periods for operator actions in the event of a loss of power, 2) large time margin to coolant boiling, which significantly reduces the likelihood of primary system over-pressurization and a consequential LOCA, and 3) a primary system that operates near atmospheric pressure (i.e., is not pressurized), so a large containment, like that required for PWRs, is not necessary. A disadvantage of SFRs is that liquid sodium metal is highly reactive with water (energetic reaction) and air (burns), which necessitates incorporation of an intermediate coolant loop between the reactor sodium coolant and the water/steam power plant and increases plant costs.

HLMC fast reactors utilize one of two possible liquid metals for the reactor coolant: pure lead (Pb) or lead-bismuth (Pb-Bi) eutectic (LBE). The safety features are similar to those of the SFR, with the additional improvement that 1) the very high boiling temperature of lead and LBE make over-pressurization of the primary system by overheating essentially impossible and 2) lead does not significantly react with water or air, which allows for a direct lead-to-water heat exchanger (i.e., no need for an intermediate loop as with SFRs). Disadvantages of HLMC fast reactors include the high cost and relative rarity of bismuth, the increased weight of lead compared to water or sodium, which increases costs associated with providing structural support and seismic protection for the primary system, and the high melting point of lead increases the complexity of refueling operations as the lead must continuously be heated to prevent solidification. This last disadvantage is somewhat offset with LBE which has a significantly lower melting point than pure lead, although LBE can be highly corrosive to most metals and is radioactive after irradiation in the reactor. HLMC fast reactors have only ever been deployed as the propulsion source for eight Soviet Union submarines, with tragic consequences in some cases, and have all since been decommissioned.

Like HTGRs, the GFRs discussed in this report utilize helium as the reactor coolant (although other materials such as carbon dioxide can be used). An important difference with HTGRs is that the fast neutron spectrum means the neutron moderator is not necessary and so this eliminates the need for the large quantities of graphite and the decommissioning challenges this poses. The fuel for GFRs is the

same as for HTGRs. The advantages and disadvantages of HTGRs were discussed in a previous section of this report. While there is significant experience with HTGRs, also discussed in the previous section, there is no practical experience with GFRs as none has ever been built, researched or otherwise.

Like MSR, the MSFR utilizes molten salts for the reactor coolant. However, fluoride salts are not a good coolant material for MSFRs because of the neutron moderation characteristics of fluorine. Chloride salts, therefore, are considered to have a potential advantage with MSFRs because chlorine is a less effective moderator of neutrons than fluorine. Similarly, the fast neutron spectrum required for MSFRs eliminates the need for the large quantities of graphite utilized in MSR and the decommissioning challenges this poses. Hence, the chemical composition of the fuel for MSFRs (e.g.,  $UCl_4$ ) would be somewhat different than that for MSR. The advantages and disadvantages of MSR were discussed in the previous section of this report. Also, as discussed for MSR, there is very little practical experience with MSR, and none with MSFRs (note, while the MSRE was designed to test fast neutron spectrum configurations, funding for the program ended before experimental testing could be performed).

Although several SFRs have been developed and deployed to limited commercial success, all fast neutron reactors are generally considered Generation IV reactors. With the exception of SFRs, these concepts are generally not expected to be available for commercial construction prior to 2030. Hence, SFR concepts meeting the definition of a SMNR (i.e., less than 300 MWe) are given more serious consideration in this assessment. Nevertheless, a brief summary of several of the other types of fast reactor concepts that are currently under development is also provided in the subsections below for information completeness.

## 7.1 Small HLMC Fast Reactor Concepts

### *ALFRED (Advanced Lead Fast Reactor European Demonstration) by Ansaldo Nucleare [Italy]*

The ALFRED is a lead-cooled fast spectrum SMNR having a design electrical/thermal capacity of 125 MW<sub>e</sub>/300 MW<sub>th</sub>. The reactor core is contained within an inner vessel that is housed within the reactor vessel (RV) that also contains the steam generators, primary coolant pumps, and control/shutdown rods. The reactor vessel (RV) sits within the safety vessel (SV) that is essentially a steel-lined reactor pit.

This reactor concept is the demonstration reactor for the larger ELFR (European Lead Fast Reactor), having a design electrical/thermal capacity of 630 MW<sub>e</sub>/1500 MW<sub>th</sub>, and which has a planned commercial deployment time period of 2040-2050. Because these parameters are outside of the scope specifications for this study, the ALFRED is not considered a candidate for further consideration in this evaluation.

### *BREST-ID-300 by Dollezhal Russian Design Institute of Power Engineering (RDIPE) [Russian Federation]*

The BREST-OD-300 reactor is a lead-cooled fast spectrum reactor having a design electrical/thermal capacity of 300 MW<sub>e</sub>/700 MW<sub>th</sub>. The reactor core, control rod system, and spent fuel assembly storage are contained within the central cavity of a concrete steel-lined vessel that also has four peripheral cavities that contain the steam generators, RCPs, and emergency cooldown systems

This reactor concept is intended to be a pilot and demonstration reactor for studying the reactor facility operation in different modes and optimizing all processes and systems that support reactor operation. It is considered a prototype for a fleet of larger 1200 MWe reactors. Since this production capacity is outside

of the scope specifications for this study, the BREST-OD-300 is not considered a candidate for further consideration in this evaluation.

#### ***G4M (Gen4 Module) by Gen4 Energy, Inc. [USA]***

The G4M reactor was formerly referred to as the Hyperion Power Module (HPM), is a LBE-cooled fast spectrum SMNR. In this concept, the sealed reactor vessel or power module houses the reactor core and primary heat transfer circuit, which is composed of a single circulation pump and intermediate heat exchangers. The reactor vessel is contained within a concrete reactor vault. A third heat exchanger, or steam generator, is located external to the reactor vault. A second reactor vault contains a "spent reactor vessel or power module." The reactor vaults and steam generator are located below ground. Figure 7.1-1 provides a conceptual drawing of the G4M reactor power plant concept.

The G4M is being advertised as an energy solution for remote locations that are too difficult or expensive to reach with traditional electrical grid systems. Its rated power output is  $25 \text{ MW}_e / 70 \text{ MW}_{th}$  and the reactor module is small enough to fit into a standard fuel transport container. The reactor module is factory sealed so there is no in-field access to the reactor core/nuclear fuel. When refueling is required, about every 10 years, the entire reactor module is removed, stored on-site in the second reactor vault for a period of cooling, and then shipped back to the factory for removal and treatment of the spent fuel. Since the power module, and used nuclear fuel, is shipped to the reactor vendor after removal from service, there would be expected to be little radiological decommissioning required at the reactor site, including no need to process the LBE coolant or manage used nuclear fuel, thereby substantially simplifying the decommissioning process.

Few standard nuclear-trained operators, SROs, would be required based on the design concept of no on-site refueling and no treatment of the coolant during reactor operations (if the sealed power module performs as specified (i.e., no leaks)). The used fuel is sealed in power modules that are swapped out every 10 years and returned to the reactor vendor, eliminating the need for trained refueling operators and minimizing radiological decommissioning activities at the reactor site.

Gen4 Energy's reactor development schedule is to first design, license, and test a  $25 \text{ MW}_e$  prototype reactor by 2030. Also, PNNL believes that licensing the power module as a transportation container/package for the fuel/spent fuel poses a difficult technical/licensing challenge that will require testing. Based on this, the G4M is judged to have a TRL of 2-3 and an estimated commercialization time window of 20+ years.

Additional information about the G4M can be found in the following references: Hyperion Power Generation 2010 and IAEA October 2013.

Conceptual Drawing of Gen4 Module (G4M)-based 25MWe Electric Power Plant

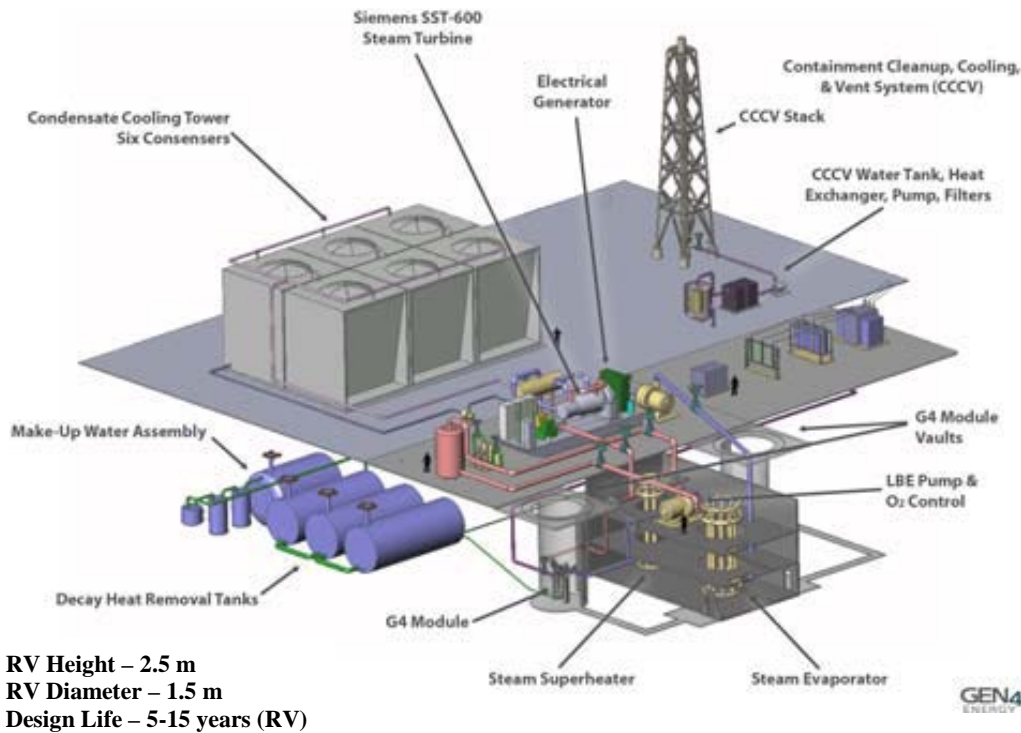

Figure 7.1-1. Conceptual Drawing of G4M Power Plant

***PEACER (Proliferation-resistant, Environment-friendly, Accident-tolerant, Continable-energy, and Economical Reactor) by Seoul National University [Republic of Korea]***

In this concept, the reactor vessel (RV), containing the reactor core, has an inner wall and outer wall (or guard vessel). External to the reactor vessel, three primary loops, each composed of a steam generator (S/G) and reactor coolant pump, remove heat from the reactor during reactor operation. The reactor vessel and primary loops are enclosed in a lined concrete cavity wherein natural circulation of air provides passive cooling of the guard vessel (referred to as the Reactor Auxiliary Vessel Air Cooling System or RVACS). This concept includes on-site pyrochemical processing of the metallic fuel. Figure 7.1-2 provides a conceptual drawing of the PEACER-300 reactor concept.

The PEACER concept was originally developed principally to provide transmutation of transuranic waste derived from the processing of spent nuclear fuel while at the same time generating electricity. The reactor design presented here has a rated power output of 300 MWe/850 MWth, and includes on-site pyrochemical processing of the metallic fuel. However, other variants of the PEACER concept are being developed, including an SMNR version referred to as URANUS-40 (Ubiquitous, Robust, Accident-forgiving, Nonproliferating and Ultra-lasting Sustainer), which has a rated power output of 40 MWe/100 MWth and utilizes natural circulation of the LBE coolant. This particular concept is being developed as a distributed power source in either a single unit or a cluster of modules for electricity, heat supply, and desalination.



No schedule has been announced for the development and deployment of the PEACER concept. Thermal-hydraulic and materials corrosion testing is currently being performed in the HELIOS Pb-Bi test loop experimental facility. Fuel irradiation testing is to be performed in a proposed small demonstration plant referred to as PASCAR, the design for which is currently under development with no announced schedule. Based on this, the PEACER is judged to have a TRL of 2-3 and an estimated commercialization time window of 20+ years.

Additional information about the PEACER can be found in the following references: IAEA 2012, IAEA October 2013, Kyoto University 2014, and CNS 2006.

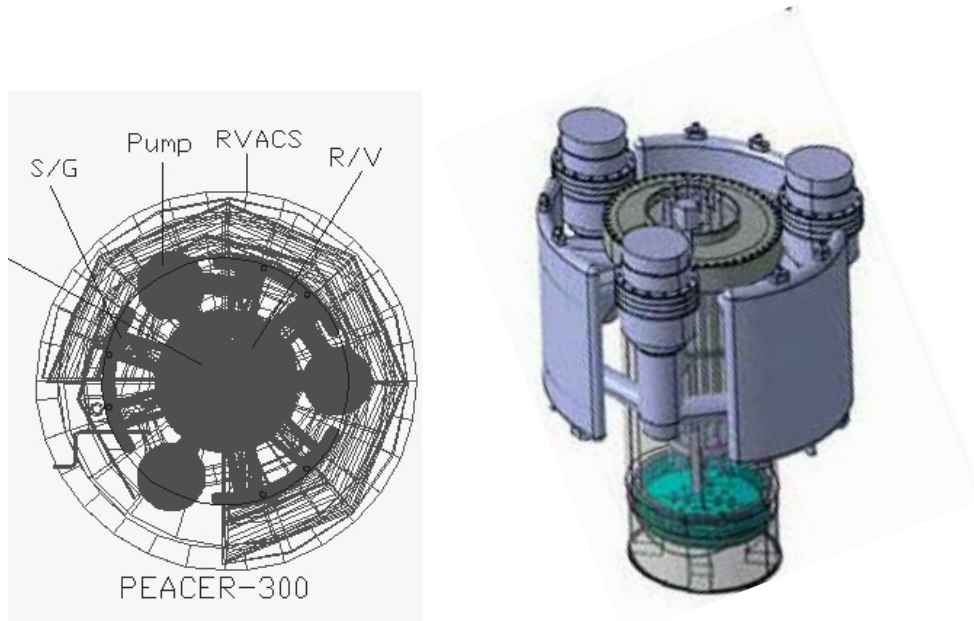

Figure 7.1-2. Conceptual Drawing of PEACER-300

### ***SVBR-100 by AKME Engineering [Russian Federation]***

The SVBR-100 reactor is a LBE-cooled fast spectrum reactor having a design electrical/thermal capacity of 101 MW<sub>e</sub>/280 MW<sub>th</sub>. In this integral reactor concept, the reactor vessel, or reactor mono-block (RMB) vessel, contains the entire primary equipment circuit, including the reactor core, 12 steam generators (SGs), and two main coolant pumps (MCPs) [with the exception that the MCP motors and the inlet/outlet portals for the SG water/steam are located external to the RMB vessel]. The RMB vessel also contains the CRDs, while the CRDMs are located external to the RMB vessel. The RMB vessel is installed inside the passive heat removal system (PHRS) tank which, in turn, is installed within a reinforced-concrete well. External to the RMB vessel and reinforced-concrete well are the four steam separators and the primary cooling system including power conversion systems. Figure 7.1-3 provides a conceptual drawing of the SVBR-100 reactor concept.

The reactor core is UO<sub>2</sub> hexagonal array fuel similar to that for LWRs. The reactor core is cooled by the forced circulation of the LBE coolant via pumps mounted on top of the RMB. Since the LBE coolant is not chemically reactive with water or air, hydrogen generation is not an issue as with LWRs. Passive

safety features allow for the passive removal of decay heat for four days without safety-related emergency AC/DC power, additional coolant, pumps, or operator actions. The SVBR-100 reactor is located above ground.

A site license was issued in February 2015 for a pilot plant to be located at Dimitrovgrad in the Ulyanovsk region near the Russian State Atomic Reactor Research Institute. Initial plans had been for startup of a pilot plant in 2019. However, in 2014 the SVBR-100 project was removed from the Federal Target Programme "Nuclear power technologies of the new generation in 2010-2015 and until 2020," and further development and construction was proceeding without federal budget funds. In September 2015 Rosatom, the SVBR-100 project developer, announced that the initial costing plans for the SVBR-100 project "turned out to be more optimistic than it is in actual fact" and that the project participants were not happy with the cost. As a result, no further federal funding is expected for the project and new investors are still being sought. AKME Engineering has provided no schedule for reactor development or fuels irradiation testing, although they may be relying on the Russian experience with LBE reactors in naval vessels to forgo the need for further testing and on the proposed pilot plant to provide the safety data required by regulators before approving commercial deployment. Based on this, the SVBR-100 is judged to have a TRL of 3-4 and an estimated commercialization time window of 20+ years.

Additional information about the SVBR-100 can be found in the following references: IAEA July 2011d, IAEA 2012, IAEA October 2013, and AKME-Engineering 2015.

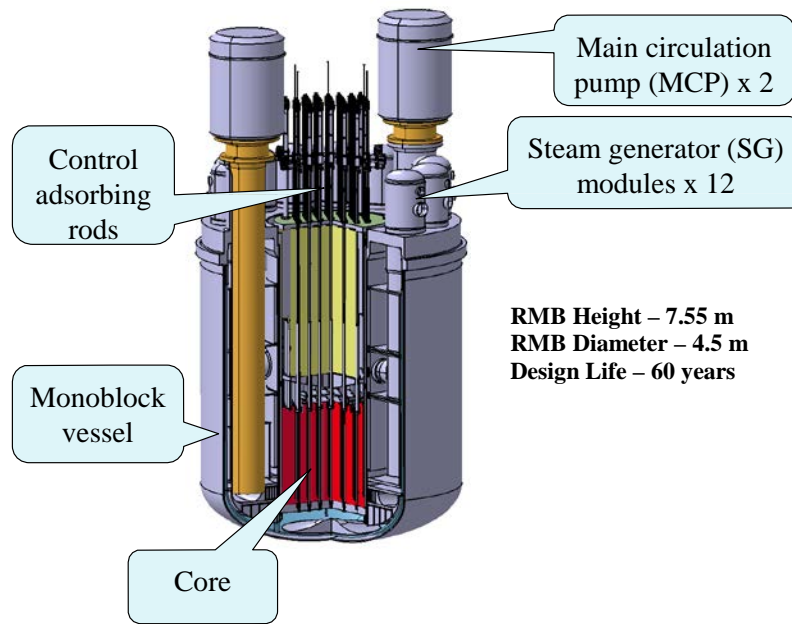

Figure 7.1-3. Conceptual Drawing of the SVBR-100 Reactor Concept

## 7.2 Small Gas-Cooled Fast Reactors Concepts

### *EM<sup>2</sup> (Energy Multiplier Module) by General Atomics [USA]*

The EM<sup>2</sup> is a high-temperature gas-cooled fast spectrum SMNR having a design electrical/thermal capacity of 265 MW<sub>e</sub> or 240 MW<sub>e</sub>/500 MW<sub>th</sub> depending on whether evaporative or dry-cooling, respectively, is used. The primary circuit consists of the Reactor System (including the reactor vessel), the Direct Reactor Auxiliary Cooling System (DRACS), and the Power Conversion Unit (PCU). The DRACS and PCU are connected to the Reactor System via individual concentric cross-vessels or ducts. The primary system is enclosed within a sealed two-chamber containment (one chamber containing the Reactor System and DRACS, the other chamber containing the PCU). The reactor chamber is enclosed in a concrete shield structure. Figure 7.2-1 provides a conceptual drawing of the EM<sup>2</sup> reactor containment and plant configuration.

Similar to the other HTGRs described in this report, the reactor core is cooled by the forced circulation of helium coolant and, since this is a fast spectrum reactor, there is no neutron moderator. However, high-density reactor-grade graphite is used as a neutron reflector. Passive safety features allow for the passive removal of decay heat (i.e., natural circulation of the helium coolant) via either of the two redundant 100% heat exchangers for an unlimited time period without safety-related emergency AC/DC power, additional coolant, pumps, or operator actions. Safeguards and security risks are substantially reduced by use of a core that does not require refueling or fuel shuffling for 32 years; which requires a higher than typical uranium enrichment of about 12%. The entire containment building is located below ground.

General Atomics has completed the conceptual design and plans to deploy a prototype within about the next decade. There is no announced schedule for submittal of the safety analysis report to the regulator, and there are no known customers for this reactor at this time. Prototype testing remains to be completed on many aspects of this reactor design. Based on this, and the fact that no GFR has ever been constructed even for research purposes, the EM<sup>2</sup> is judged to have a TRL of 3-4 and an estimated commercialization time window of 20+ years.

Additional information about HTR-PM can be found in the following references: IAEA September 2012, Waste Management Symposia 2013, ANS July 2014, ANS December 2014c, DOE/NRC 2016, PennWell Corporation 2015, GA 2015.

## 7.3 Small Molten Salt Fast Reactors Concepts

No molten salt fast reactors, either experimental/test reactors or otherwise, have ever been deployed. Recently, however, it was announced that Southern Company Services of the USA, partnering with TerraPower and others, was funded by the U.S. DOE to conduct research on a chloride salt fast reactor concept referred to as the Molten Chloride Fast Reactor (MCFR). Total funding possible under the award is \$40 million. No details have been published regarding a conceptual design for this reactor concept, including whether it would even be categorized as an SMNR. Furthermore, development and commercialization is estimated to be 20+ years.

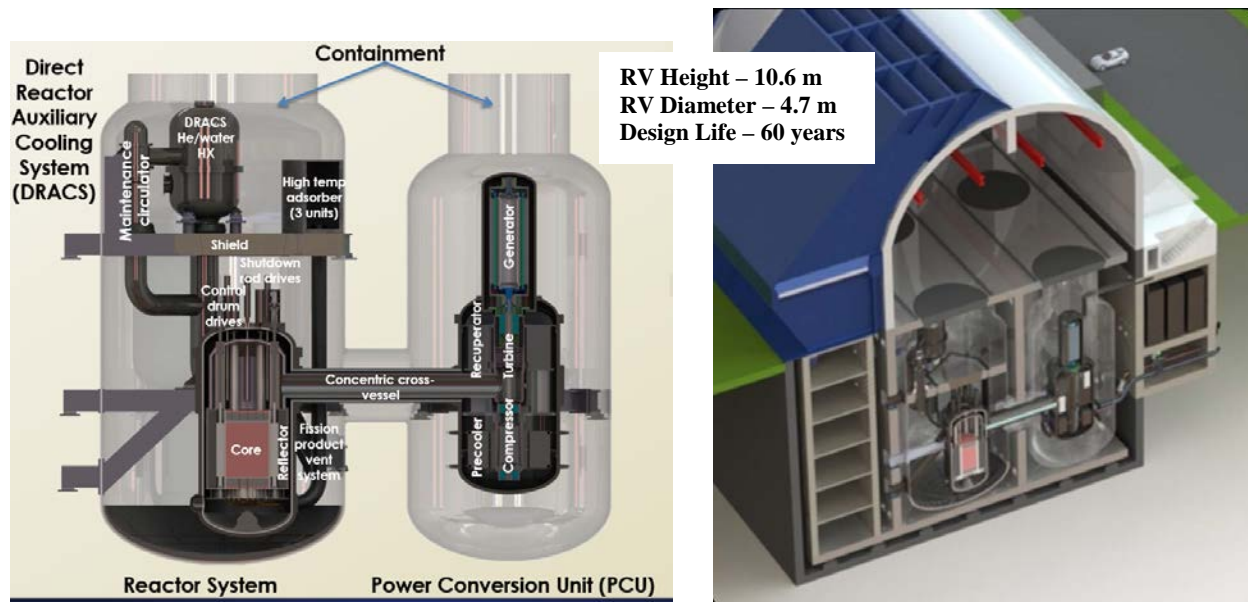

Figure 7.2-1. Conceptual Drawing of EM<sup>2</sup> Reactor Containment and Plant Configuration

## 7.4 Small Sodium Fast Reactor Concepts

### *4S (Super-safe, Small and Simple) by Toshiba [Japan]*

The 4S is a sodium-cooled fast spectrum SMNR having two possible design electrical/thermal capacities of 10 MW<sub>e</sub>/30 MW<sub>th</sub> and 50 MW<sub>e</sub>/135 MW<sub>th</sub>. The reactor vessel contains all primary system components, including the intermediate heat exchangers, primary electromagnetic pumps (EMP), moveable reflectors, ultimate shutdown rod, radial shielding assemblies, core support plate, coolant inlet modules, and fuel subassemblies. The reactor vessel is enclosed within the guard vessel and top dome, which is surrounded by a reinforced concrete reactor building. Each plant is designed to contain a single reactor module. Figure 7.4-1 provides a conceptual drawing of the 4S reactor and plant configuration.

The reactor core is cooled by the forced circulation of liquid sodium metal coolant and, since this is a fast spectrum reactor, there is no neutron moderator. The 4S has an inherent safety feature that acts to automatically shutdown the reactor without operator intervention when the temperature of the liquid sodium metal increases above the design temperature (i.e., SFRs have negative temperature and void coefficients). A second inherent safety feature is that the reactor operates at low pressure (i.e., the primary system is not pressurized), hence if sodium leakage occurs (i.e., LOCA) the leak rate will be slow. Passive safety features include two residual heat removal systems (RHRSs) and a large sodium inventory that passively removes decay heat for an unlimited time period without safety-related emergency AC/DC power, additional coolant, pumps, or operator actions. In the event of a LOCA and loss of heat sink, the RHRS can remove decay heat passively with air convection. Consequently there is no need for an active emergency core cooling system(s) in the design. Safeguards and security risks are substantially reduced by use of a core that does not require refueling or fuel shuffling for 30 years; which requires a higher than typical uranium enrichment of up to 19%. The reactor building containing the guard vessel and top dome is located below ground.

Toshiba has completed the detailed design and is looking for customers. There is no announced schedule for submittal of the safety analysis report to the regulator, and pre-application discussions with the U.S. NRC ended in 2010. The reactor is being actively marketed. Most component and fuel testing necessary to receive the design approval have been completed. Based on this, the 4S is judged to have a TRL of 6-7 and an estimated commercialization time window of 5-10 years.

Additional information about 4S reactor can be found in the following references: IAEA March 2013a, IAEA October 2013, NRC March 2011, and WNA 2016.

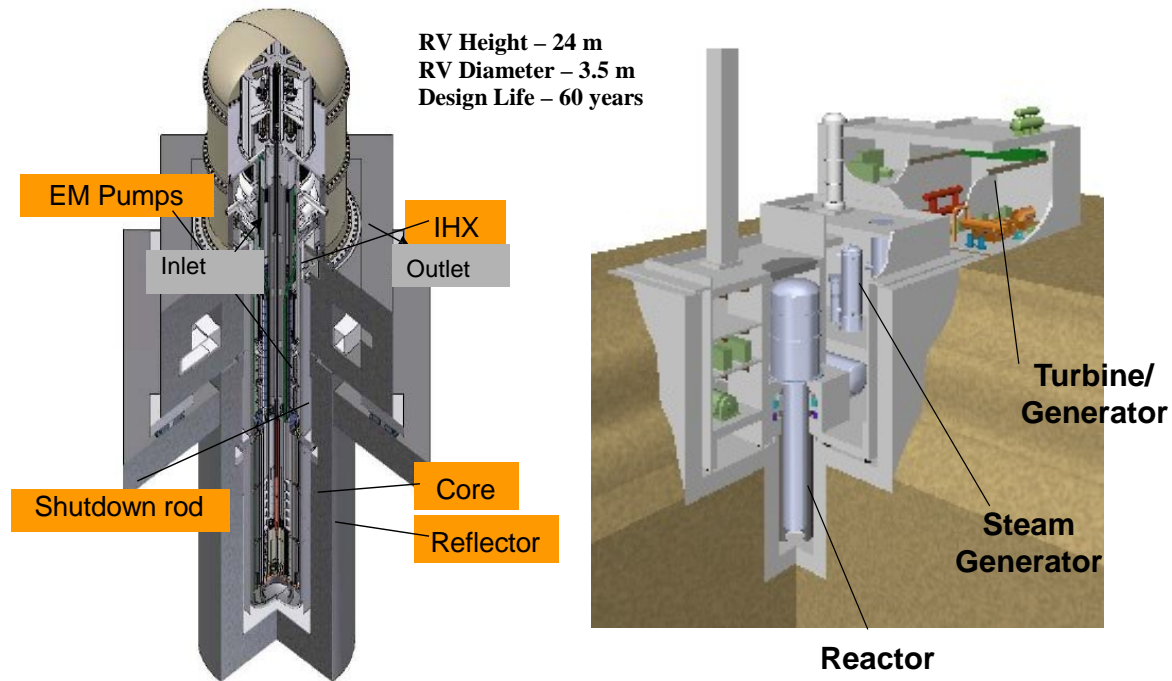

Figure 7.4-1. Conceptual Drawing of the 4S Reactor and Plant Configuration

***MBIR (Multipurpose Fast-neutron Research Reactor) by NA Dollezhal Research and Development Institute of Power Engineering Dollezhal (NIKIET) [Russian Federation]***

The MBIR is a sodium-cooled fast spectrum reactor having a design electrical/thermal capacity of up to 60 MW<sub>e</sub>/150 MW<sub>th</sub>. The reactor vessel contains the reactor core and both vertical and horizontal access ports for conducting experimental research. The reactor vessel is enclosed within a safeguard vessel to prevent loss of sodium. The intermediate heat exchangers and associated piping systems are located external to the reactor/safeguard vessels. The entire reactor facility is located above ground.

The MBIR is being developed for various research activities including advanced nuclear fuel and absorber materials, cyclic and emergency modes of operation, studies related to closed fuel cycles, radiation tests of advanced structural materials, study of new and modified liquid metal coolants, validation of new equipment, production of radioisotopes, and use of neutron beams for medical applications. Since this reactor concept is not intended for commercial deployment, the MBIR is not considered a candidate for further consideration in this evaluation.

***PGSFR (Prototype Gen-IV Sodium-cooled Fast Reactor) by Korea Atomic Energy Research Institute (KAERI) [Republic of Korea]***

The PGSFR is a sodium-cooled fast spectrum small nuclear reactor (not necessarily an SMNR) having a design electrical/thermal capacity of 150 MW<sub>e</sub>/392 MW<sub>th</sub>. A principal design objective of the PGSFR concept is to demonstrate the transmutation of transuranic waste derived from the processing of spent nuclear fuel, as part of an advanced fuel cycle system, while at the same time generating electricity. The reactor vessel contains the reactor core, submerged in a large sodium pool, and much of the primary heat transport system (PHTS), which consists of two loops each having two intermediate heat exchangers (IHXs), a reactor coolant pump, and associated piping. The reactor vessel is contained within the containment vessel, which in turn is contained within a concrete vault. External to the containment vessel and vault is the control rod drive mechanism (CRDM), the two PHTS reactor coolant pumps, intermediate heat transport system (IHTS), consisting of two loops each having one pump and steam generator, and the primary cooling system (PCS) including power conversion systems. This concept includes on-site pyrochemical processing of the metallic fuel. Figure 7.4-2 provides a conceptual drawing of the PGSFR plant configuration. Figure 7.4-3 provides a mass/heat balance for the PGSFR.

The reactor core is cooled by the forced circulation of liquid sodium metal coolant and, since this is a fast spectrum reactor, there is no neutron moderator. The PGSFR has an inherent safety feature that acts to automatically shutdown the reactor without operator intervention when the temperature of the liquid sodium metal increases above the design temperature (i.e., SFRs have negative temperature and void coefficients). A second inherent safety feature is that the reactor operates at low pressure (i.e., the primary system is not pressurized), hence if sodium leakage occurs (i.e., LOCA) the leak rate will be slow and the potential for pressurized leaks is likely eliminated (still being evaluated). Passive safety features include a passive decay heat removal system and a large sodium inventory that passively removes decay heat for an extended (undefined) time period without safety-related emergency AC/DC power, additional coolant, pumps, or operator actions. The reactor building containing the reactor vessel and PHTS is located above ground.

A preliminary design of the PGSFR has been completed. The schedule for deployment of the PGSFR is: site selection is to be made in 2018, design approval by the regulator by 2020, construction start in 2022, and construction completion in 2028. Thermal-hydraulic testing of reactor and cooling systems, fuel development testing, including irradiation testing, is scheduled to be completed in 2020. Based on this, the PGSFR is judged to have a TRL of 4-5 and an estimated commercialization time window of 15-20 years.

Additional information about PGSFR can be found in the following references: ANS June 2016a, ANS June 2016b, ANS July 2016, IAEA February 2013, IAEA October 2013, BusinessKorea January 2016, and Elsevier August 2016.



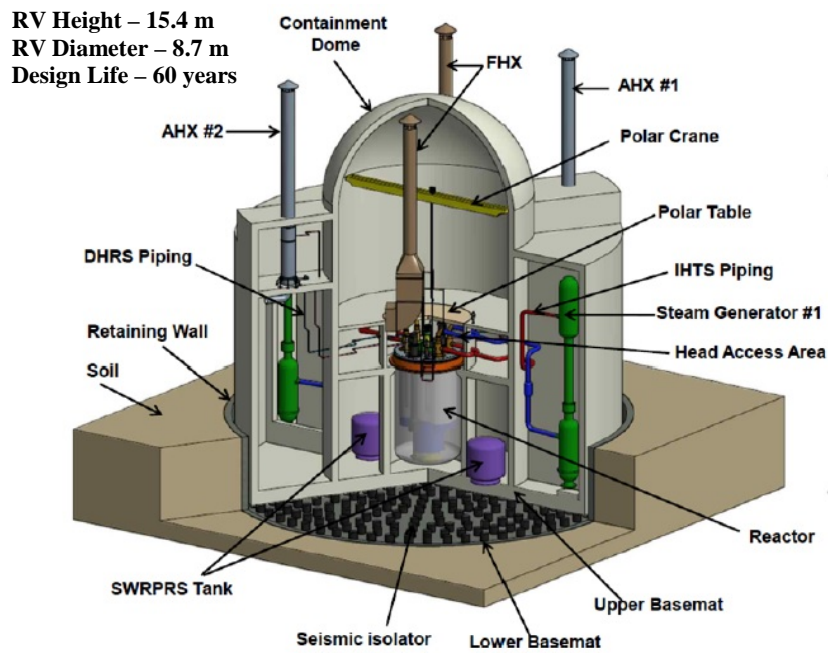

Figure 7.4-2. Conceptual Drawing of the PGFSR Plant Configuration

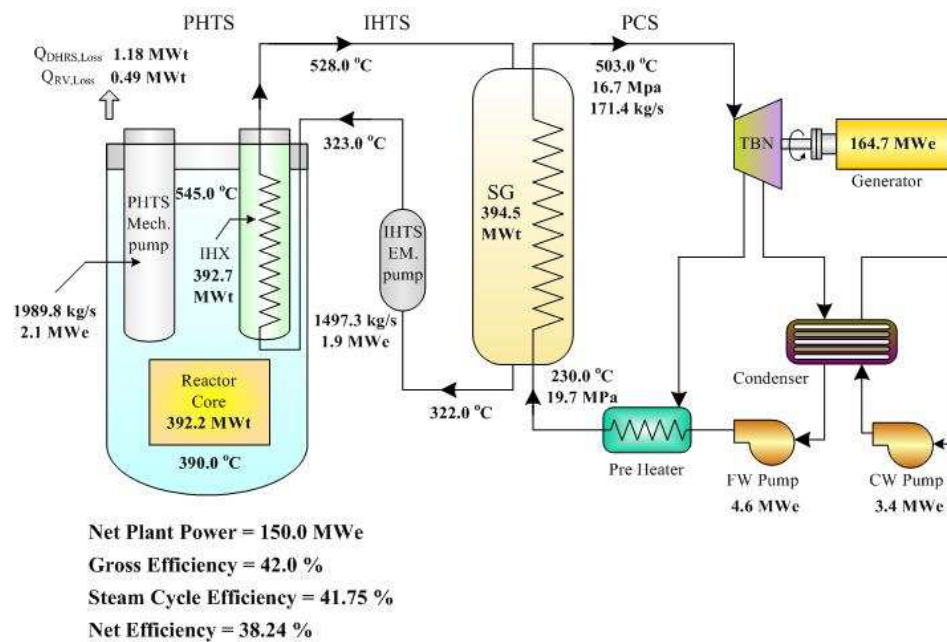

Figure 7.4-3. Mass/Heat Balance of the PGFSR

### ***PRISM (Power Reactor Innovative Small Module) by GE-Hitachi [USA]***

The PRISM is a sodium-cooled fast spectrum SMNR having a design electrical/thermal capacity of 311 MW<sub>e</sub>/840 MW<sub>th</sub>. A principal design objective of the PRISM concept is to recycle used nuclear fuel (UNF) from thermal neutron reactors (i.e., burning plutonium from reprocessed UNF). The reactor vessel contains the reactor core, submerged in a large sodium pool, the entire primary heat transport system (PHTS), the control rod drives (CRDs), the ultimate shutdown drives, and an In-Vessel Transfer Machine. The PHTS consists of the reactor core, the hot and cold sodium pools, two intermediate heat exchangers (IHXs) and four electromagnetic (EM) primary pumps that are suspended from the reactor closure (single plate cover to the reactor vessel), and associated piping. The reactor vessel is contained within the containment vessel, which in turn is contained within the reactor silo (concrete vault). External to the containment vessel and reactor silo is the control rod drive mechanisms (CRDMs), intermediate heat transport system (IHTS), consisting of two loops each having one EM pump and steam generator, and the primary cooling system (PCS) including power conversion systems. This concept includes as an option on-site pyrochemical processing of the metallic fuel. Figure 7.4-4 provides a conceptual drawing of the PRISM plant configuration. Figure 7.4-5 provides a conceptual drawing of the PHTS.

The reactor core is cooled by the forced circulation of liquid sodium metal coolant and, since this is a fast spectrum reactor, there is no neutron moderator. The PRISM has an inherent safety feature that acts to automatically shutdown the reactor without operator intervention when the temperature of the magnetic latch for the ultimate shutdown control rods exceeds the magnetic Curie point temperature<sup>20</sup>. Automatic shutdown is further enhanced by negative temperature and void coefficients inherent to SFRs. Another inherent safety feature is that the reactor operates at low pressure (i.e., the primary system is not pressurized), hence if sodium leakage occurs (i.e., LOCA) the leak rate will be slow (not pressurized). Passive safety features include a passive decay heat removal system and a large sodium inventory that passively removes decay heat for an indefinite time period without safety-related emergency AC/DC power, additional coolant, pumps, or operator actions. The entire reactor containment is located below ground.

An advanced conceptual design of the PRISM has been completed and the detailed design is being developed. A deployment schedule is not yet available because there is no customer at this time. GE-Hitachi is actively seeking first deployment in the United Kingdom to burn excess plutonium from the reprocessing of UNF. The first reactor would be the prototype reactor. Fuel development testing is considered essentially complete based on irradiation testing performed in the EPR-II and TREAT reactors at INL in the 1980s/1990s. Thermal-hydraulic testing of reactor and cooling systems remains to be completed with no announced schedule. Based on this, the PRISM is judged to have a TRL of 5-6 and an estimated commercialization time window of 10-15 years.

Additional information about PRISM can be found in the following references: ANS May 2012, ANS December 2014d, GE Hitachi 2016, IAEA 2012, IAEA October 2013.

---

<sup>20</sup> The magnetic Curie point temperature is the temperature at which the latch material loses its magnetic properties.



1. Steam Generator
2. Reactor Vessel Auxiliary Cooling Sys
3. Refueling Enclosure Building
4. Steam Tunnel To Turbine
5. Reactor Protection System Modules
6. Seismic Isolation Bearing
7. Reactor Module
8. Primary Electromagnetic Pump
9. Reactor Core
10. Intermediate Heat Exchangers
11. Lower Containment Vessel
12. Upper Containment Building
13. Sodium Dump Tank
14. Intermediate Heat Transfer System
15. Steam Outlet Piping
16. Feedwater Return Piping

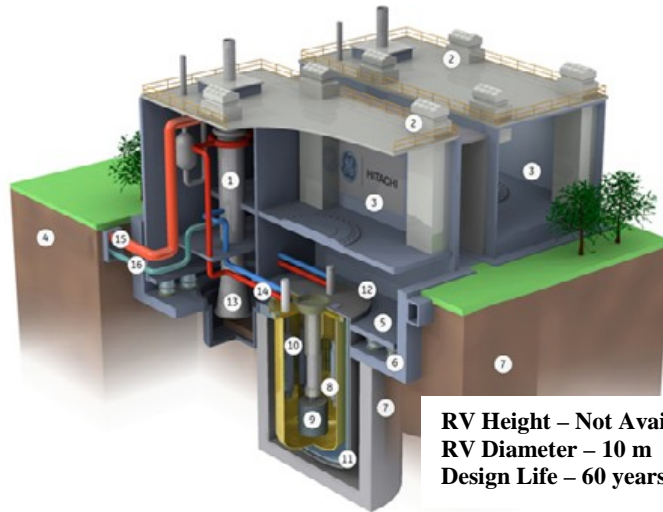

Figure 7.4-4. Conceptual Drawing of the PRISM Plant Configuration

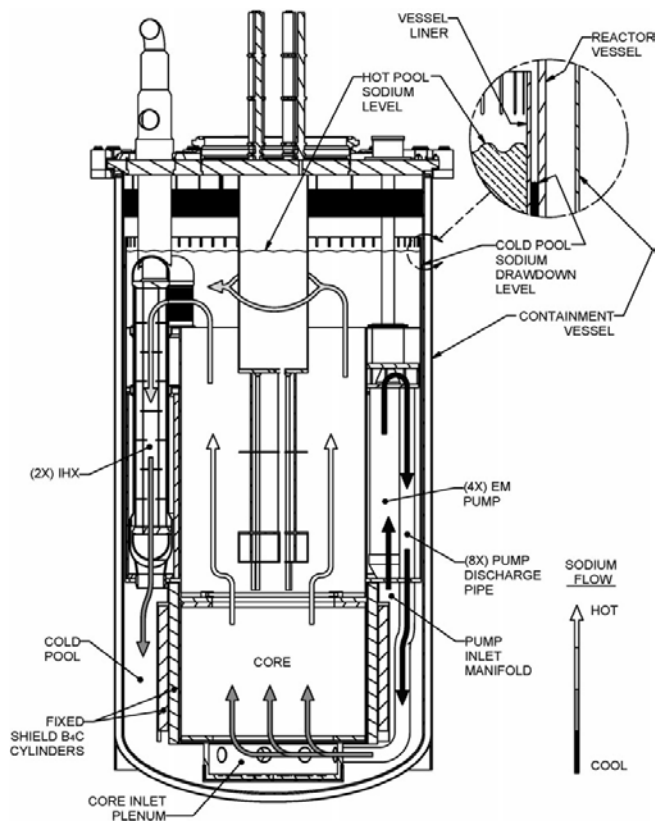

Figure 7.4-5. Conceptual Drawing of the PHTS

## 7.5 Operational Experience with Sodium Fast Reactors

About 20 power-producing SFRs have been built and operated around the world, of which 9 had as a main objective to generate electric power (France – 2, Japan – 1, Kazakhstan – 1, Russian Federation – 2, USA – 2, United Kingdom - 1). Of these, only two SFRs in the Russian Federation (BN-600 and BN-800) and one reactor in Japan (Monju) remain in operation today [although others are currently being built]. None of these reactors, however, were designed with the passive safety features being incorporated into the concepts described in the previous section. Also, none of these power demonstration SFRs experienced a serious safety event during its operation (i.e., there are no known events that would be rated greater than 3 on the INES scale wherein a significant radiological release occurred). Nevertheless, the following three events are noteworthy:

- Enrico Fermi Nuclear Generating Station Unit 1 (69 MW<sub>e</sub>) in the USA. On October 5, 1966, Fermi 1, a prototype fast breeder reactor, suffered a partial fuel meltdown when two of the 92 fuel assemblies were partially damaged, although no radioactive material was released. The main cause of the partial meltdown was due to a temperature increase caused by a blockage in one of the lower support plate orifices that allowed the flow of liquid sodium into the reactor. The blockage caused an insufficient amount of coolant to enter the fuel assembly; this was not noticed by the operators until the core temperature alarms sounded. Following an extended shutdown that involved fuel replacement, repairs to the vessel, and cleanup, Fermi 1 restarted in July 1970 and reached full power. Due of lack of funds and aging equipment it was shut down permanently on November 27, 1972.
- BN-350 (350 MW<sub>e</sub>) in Kazakhstan (designed/built by the former Soviet Union). In 1973 or 1974 a major sodium fire occurred when steam generator pipes depressurized and water entered the secondary cooling loop, mixing with the sodium and causing a water-sodium explosion and subsequent fire. The fire is reported to have lasted two hours and to be rated as Level 1 on the INES scale (no radioactivity release since the fire was on the non-radioactive secondary cooling loop).
- Monju NPP sodium-cooled fast reactor (280 MW<sub>e</sub>) in Japan. On December 8, 1995, a thermo-well broke allowing several hundred kilograms of sodium coolant to leak out onto the floor below the thermos-well. Upon contact with air, the liquid sodium reacted with oxygen and moisture in the air, filling the room with caustic fumes and producing temperatures of several hundred degrees Celsius. The heat was so intense that it warped several steel structures in the room. The leak occurred in the plant's secondary cooling system, so the sodium was not radioactive and there was no release of radioactive material (hence, this incident would be rated 3 or less on the INES scale). However, Power Reactor and Nuclear Fuel Development Corporation, the semi-governmental agency then in charge of Monju, tried to cover up the extent of the accident and resulting damage. This cover-up included falsifying reports and the editing of a videotape taken immediately after the accident, as well as issuing a gag order that aimed to stop employees revealing that tapes had been edited. As a consequence, the reactor was only given approval to restart almost 15 years later in 2010. However, the reactor only operated for a few months before

another incident<sup>21</sup> shut the plant down again. The reactor has not operated since, and the Japanese Government is currently giving serious consideration to permanent shutdown and decommissioning of this reactor.

In addition, SFRs have experienced a number of operational issues that have significantly impacted plant operations, in some cases resulting in extended periods of reactor shutdown. Major types of problems experienced are as follows:

- Sodium leaks in the primary (radioactive) and secondary (non-radioactive) coolant loops. The majority of these types of incidents generally occur early in the operation of the reactor, declining over time as improvements are made to systems/components and operator training. Depending on the magnitude of the leak and its location, consequences can range from no impact (i.e., the reactor continues to operate while the issue is resolved) to short duration reactor shutdowns to long duration reactor shutdowns. Examples of specific experience:
  - BN-600 reactor. Located in the Russian Federation, this is a 600 MW<sub>e</sub> plant that has been operating since 1981. Up to 2013, a total of 27 incidents had been reported, with none since 1993. These incidents reportedly have had little impact on plant operations.
  - Phénix reactor. Located in France, this was a 255 MW<sub>e</sub> plant that operated from 1973-2009, although the reactor only operated sporadically after 1990. Through 2003, a total of 23 incidents had been reported. These incidents are cited as one of the major reasons the plant only operated at 2/3 of rated power for long time periods, and for major safety upgrades made to the plant between 1998 and 2003.
  - Super-Phénix reactor. Located in France, this was a 1200 MW<sub>e</sub> plant that operated from 1986-1998. A major sodium leak from the used fuel storage drum resulted in a 2-year shutdown.
- Sodium-water reactions in the steam generators (non-radioactive cooling loop). As with sodium leaks in the previous bullet, the majority of these types of incidents generally occur early in the operation of the reactor, declining over time as improvements are made to systems/components and operator training. Like sodium leaks generally, these types of incidents can have a significant impact on plant operations. Examples of specific experience:
  - BN-600 reactor: Up to 2013, a total of 14 sodium-water reactions resulting in fires had been reported, nearly ½ occurred in the first year of operation. The last occurrence was reported to be in 1991. These incidents reportedly have had little impact on plant operations.
  - Phénix: A total of five incidents were reported through 2003. These incidents are reported to have resulted in six months of reactor shutdown and nine months of reactor operation at 2/3 of rated power.

---

<sup>21</sup> On August 26, 2010, the In-Vessel Transfer Machine (IVTM) fell into the reactor when being removed after a scheduled fuel replacement operation. It took almost one year (June 24, 2011) to retrieve the IVTM from the reactor vessel. See Reference: Reuters News Agency, June 23, 2011, “Fallen device retrieved from Japan fast-breeder reactor” (<http://www.reuters.com/article/us-japan-nuclear-monju-idUSTRE75N0H320110624>).

- Sodium oxide contamination in the liquid sodium coolant. The Super-Phénix reactor experienced a major incident in which the primary cooling loop sodium was contaminated due to exposure to impure argon cover gas (which had been exposed to air), which produced a significant amount of sodium oxide contamination. This resulted in a 2-year shutdown to clean the contaminated sodium and make other corrective actions.
- Reactivity transients. On several occasions between 1976 and 1990, the Phénix reactor was automatically shutdown when the negative reactivity threshold was exceeded. After the last incident in 1990, an expert committee was set up and an extensive study was initiated to determine the cause of these reactivity transients. The reactor was shutdown from 1990 to 1993 while this study was performed.

It is noted that a large experimental SFR located in the USA, the Fast Flux Test Facility (FFTF) having a design capacity of 400 MW<sub>th</sub> (it did not produce electricity), which operated from 1982 to 1992, did not experience any of the safety issues identified in this section. This was an advanced SFR for the purpose of testing advanced nuclear fuels, materials, components, plant operations and maintenance protocols, and reactor safety designs. It was permanently shutdown after the U.S. Government determined it was no longer needed for research purposes. Having not experienced any of the above safety issues suggests that a careful and disciplined design combined with good conduct of operations can prevent, or significantly reduce the likelihood of, the above types of events.

Additional information about operational experience of SFRs can be found in the following references: IAEA 2007, IAEA March 2013b, International Panel on Fissile Materials 2010, and ORNL 1980.

## 8.0 SMNR Ranking Model

Each of the SMNR concepts described in the previous sections were evaluated using Decision Analysis techniques with an end goal to develop an overall ranking of each concept relative to a pre-defined set of attributes or criteria. These techniques were chosen because they make explicit the rationale by which the reactor concepts were evaluated, promote clarity in the thought process for ranking the concepts, and aided the specification of the information that needed to be developed for each concept in order to perform the evaluation. The use of Decision Analysis techniques for this study is appropriate because:

- It provides a defensible basis for evaluating each reactor concept and documenting the process,
- It specifies what criteria are to be considered, how they are measured and evaluated, and their relative importance, and
- It provides the underlying rationale for making a path-forward decision regarding further pursuing deployment of SMNRs in Alberta.

However, while Decision Analysis provides useful input in the consideration of alternative reactor concepts, it is not practical to consider every input that must be considered by decision makers. Hence, while it may be a useful tool to help decision makers eliminate or screen reactor concepts that are not good candidates for implementation in Alberta, and help inform the decision process in other ways, it cannot replace the measured judgement necessary in making well-informed decisions.

With this caveat, PNNL and AI worked together to jointly develop the “SMNR Ranking Model,” or Decision Analysis tool, to evaluate each of the reactor concepts in a structured format using the same, technology-neutral, criteria for each reactor concept. Initially, the criteria important to AI were defined in the SOW (see Attachment A). As the evaluation proceeded, the criteria was refined in certain cases to reflect the practicality of the information available on each reactor concept.

To support the evaluation, an Excel<sup>®</sup> database was developed to contain the design details, development schedule and status, and other characteristics of each reactor concept necessary for this analysis. The database was developed using only publicly-available information readily accessible to PNNL. Due to the limited budget, no reactor vendors were contacted to provide information to support this analysis.

A two-step analysis method was developed to provide 1) a ranking of each SMNR concept based on full compliance with the evaluation criteria and 2) a ranking of each SMNR concept based on full and partial compliance with the evaluation criteria. Each of the methods is described in this section.

### 8.1 Ranking by Full Compliance with Individual Criteria

The “Full Compliance Ranking Model” was developed to provide a simple assessment of whether or not each reactor concept meets the high-level objectives or criteria important to AI. A total of 13 criteria were developed, representing 11 subject categories. The subject categories and associated criteria are provided below:

- Commercial Deployment – Is the reactor concept commercially deployable by the year 2030?

- Steam Quality – Is the quality of the steam directly produced by the reactor sufficient to support SAGD for oil recovery from Canada’s oil sands (i.e., steam pressure and temperature is  $\geq 9$  MPa and  $315^{\circ}\text{C}$ , respectively)?
- TRL – Is the TRL or development state of the reactor concept  $\geq 5$  (i.e., component validation has been performed in the relevant reactor operating environment)?
- Steam Production – Is the steam production capacity of the reactor  $\geq 655,200$  kg/hr (i.e., the steam production rate required for a typical SAGD operation)?
- Power Rating – Is the power rating (electricity production capacity) of the reactor  $\geq 11$  MW<sub>e</sub> and  $\leq 18$  MW<sub>e</sub> (i.e., the amount of electricity required for a typical SAGD operation)?
- Safety (2 criteria) – 1) Does the reactor design incorporate advanced inherent/passive safety features to prevent/mitigate severe accidents? 2) Does the reactor not use a coolant that is chemically-reactive with air or water?
- Spent Fuel Management (2 criteria) – 1) Does the used nuclear fuel require on-site treatment after discharge? 2) Does the reactor vendor disposition<sup>22</sup> the used nuclear fuel? [Note: these questions address the lack of infrastructure in Alberta for used fuel management/disposition.]
- LLW/ILW Management – Does the reactor plant concept generate little or no LLW/ILW during plant operations? [Note: this question addresses the lack of infrastructure in Alberta for storage/treatment/disposal of LLW/ILW.]
- Decommissioning – Has decommissioning of the reactor type been demonstrated?
- Alberta Adaptability – Does the reactor plant concept require on-site trained nuclear operators? [Note: this question addresses the challenge of locating highly-trained nuclear plant operators in remote Alberta communities.]
- Levelized Cost of Electricity (LCOE) – Is the estimated LCOE (based on U.S. 2015 \$) for the reactor concept competitive with the LCOE for combined-cycle natural gas plants?

The answer to each of the above questions is either “YES” or “NO.” For the purposes of the quantitative ranking model, an answer of “YES” is assigned a numerical value of “1” while an answer of “NO” is assigned a numerical value of “0.”

Each of the topic areas was assigned a weight from 1 and 10 by AI to reflect the relative importance of each of the criteria to the reactor concept selection decision. The weights assigned are as follows:

- Commercial Deployment – 8

---

<sup>22</sup> The term disposition refers all activities associated with managing the used fuel after it is discharged from the reactor, including interim storage at the reactor site or away from the reactor site, chemical processing to remove materials for reuse (i.e., recycling), treatment to stabilize the used fuel or waste products generated from recycling, and final disposal.

- Steam Quality – 10
- TRL – 6
- Steam Production – 9
- Power Rating – 9
- Safety – 10, subdivided into the two safety criterion as follows
  - Advanced Inherent/Passive Safety Features – 7
  - Chemically-reactive Coolant – 3
- Spent Fuel Management – 8, subdivided into the two spent fuel management criterion as follows:
  - Requires On-site Treatment After Discharge – 4
  - Reactor Vendor Dispositions Used Nuclear Fuel – 4
- LLW/ILW Management – 5
- Decommissioning – 5
- Alberta Adaptability – 9
- LCOE – 9

The quantitative ranking of each reactor concept was then determined by summing the product of the weights and “0” or “1” depending on the answers to each question, and then dividing by the sum of the weights (i.e., “79”). Hence, a total summed score of “1” is the maximum possible rank if the answer to all questions is “YES.” This model is represented by the following equation:

$$\text{Total Score or Rank} = \frac{\sum_{i=1}^{13} S_i \times w_i}{\sum_{i=1}^{13} w_i} \quad (\text{Eqn. 8-1})$$

where:

$S_i$  = assigned score for each of the 13 criteria (“0” or “1”)

$w_i$  = weight factor for each of the 13 criteria (from 1 to 10)

## 8.2 Ranking by Full and Partial Compliance with Individual Criteria

The “Full and Partial Compliance Ranking Model” was developed to provide a more detailed assessment or measure of the degree to which each of the criteria are achieved. The same criteria and weights as described above for the Full Compliance Ranking Model are used for this assessment. However, rather than just a binary score of “YES” or “NO,” scores from 1 and 10 are assigned to reflect partial compliance with the criteria. In order to assign scores from 1 and 10, each of the criteria were further broken down into specific criterion against which data could be collected. Hence, not all possible scores from 1 and 10 were necessarily assigned a specific criterion for each of the criteria. For example, for Steam Quality, only scores of 1 or 10 are possible while for Commercial Deployment, all integer scores from 1 and 10 are possible. The specific criterion and associated score for each criteria are summarized in Table 8.2-1.

As with the “Full Compliance Ranking Model,” the quantitative ranking of each reactor concept was then determined by summing the product of the weights and the scores assigned to each of the criteria, and then dividing by the sum of the weights (i.e., “88”). This result was then divided by 10 so as to put the calculated rank on the same scale as the “Full Compliance Ranking Model.” Hence, a total summed score of “1” is the maximum possible rank if the score assigned to each of the criteria is “10.” This model is represented by the following equation:

$$\text{Total Score or Rank} = \frac{\sum_{i=1}^{13} S_i \times w_i}{10 \times \sum_{i=1}^{13} w_i} \quad (\text{Eqn. 8-2})$$

where:

$S_i$  = assigned score for each of the 13 criteria (from 1 to 10)

$w_i$  = weight factor for each of the 13 criteria (from 1 to 10, and same as Eqn. 8-1)



Table 8.2-1. Scoring Criteria

Score	Commercial Deployment	Steam Quality	TRL	Steam Production	Power Rating	Safety – Inherent/Passive Safety Features	Safety – Chemically-reactive Coolant	Spent Fuel Management – On-site Treatment
1	Concept Description	SAGD quality steam produced with energy upgrade technology	1-2	Direct Produced Steam Quality < 1 MPa	Single Module > 100 MWe	< 36 hours grace period	Coolant that is chemically-reactive with air/water is used	Continuous on-line refueling
2	Testing to Support Conceptual Design			Direct Produced Steam Quality ≥ 1 MPa, < 3 MPa		36+ hours grace period		≤ 18 month discharge cycles
3	Conceptual Design Completed							
4	Basic Design in Process		2-3	Direct Produced Steam Quality ≥ 3 MPa, < 5 MPa	Single Module > 50 MWe and ≤ 100 MWe	72+ hours grace period		> 18-36 month discharge cycles
5	Basic Design Completed							
6	Detailed Design in Process (testing)		3-4	Direct Produced Steam Quality ≥ 5 MPa, < 7 MPa	Single Module > 30 MWe and ≤ 50 MWe	7+ days grace period		> 3-5 year discharge cycles
7	Detailed Design Completed							
8	Prototype under Construction		4-5	Direct Produced Steam Quality ≥ 7 MPa, < 9 MPa	Single Module > 18 MWe and ≤ 30 MWe	Unlimited grace period		> 5 year discharge cycles
9	Prototype in Operation							> 25 year discharge cycles
10	Licensed in US, Canada, or Europe	SAGD quality steam produced directly from SMNR	≥ 5	Direct Produced Steam Quality ≥ 9 MPa	Single Module > 11 MWe and ≤ 18 MWe	Natural circulation; unlimited grace period	Coolant that is chemically-reactive with air/water is not used	Spent fuel removed from site

Table 8-2.1. Scoring Criteria (Continued)

Score	Spent Fuel Management – Vendor Disposition	LLW/ILW Management	Decommissioning	Alberta Adaptability	LCOE (based on U.S. 2015 \$) <sup>23</sup>
1	Burnup < 10 gigawatt-days (GWd)/ton, thereby maximizing volume	LLW/ILW generated during operations potentially contain significant activation products having >> 50 yr half-life	LLW/ILW with half-life ( $T_{1/2}$ ) > 100 years and coolant/moderator requires specialized treatment/stabilization	Senior Reactor Operator (SRO), nuclear plant, refueling, and fuel processing operators required	> Not competitive (> 130 \$/MW-hr)
2	Burnup $\geq$ 10 GWd/ton			SRO, nuclear plant continuous refueling operators	> 120 \$/MW-hr and $\leq$ 130 \$/MW-hr
3	Burnup $\geq$ 30 GWd/ton				Competitive with conventional gas turbine (> 110 \$/MW-hr and $\leq$ 120 \$/MW-hr)
4	Burnup $\geq$ 60 GWd/ton		LLW/ILW with $T_{1/2}$ > 100 years and coolant/moderator requires specialized treatment/stabilization	SRO, nuclear plant, refueling, and specialized coolant handling operators	Competitive with advanced large nuclear (> 100 \$/MW-hr and $\leq$ 110 \$/MW-hr)
5		LLW/ILW generated during operations mostly fission/activation products having < 50 year half-life; use of $UO_2$ fuel			Competitive with NuScale SMNR (> 90 \$/MW-hr and $\leq$ 100 \$/MW-hr)
6	Burnup $\geq$ 100 GWd/ton	LLW/ILW generated during operations mostly fission/activation products having < 50 year half-life; use of higher integrity metallic fuel		SRO, nuclear plant and periodic (2-year) refueling operators (vendor supported)	Competitive with combined cycle natural gas with carbon sequestration (CCS) (> 80 \$/MW-hr and $\leq$ 90 \$/MW-hr)
7			LLW/ILW with $T_{1/2}$ < 100 years and coolant/moderator does not require specialized treatment/stabilization		> 70 \$/MW-hr and $\leq$ 80 \$/MW-hr
8	Very high burnup (maximizes use of fuel, thereby minimizing volume)	Low volume of LLW/ILW generated during operations because of high integrity, fail-safe fuel; mostly fission/activation products having < 50 year half-life		SRO, few nuclear plant operators, and no refueling operators (vendor provided for very long refueling cycles)	Competitive with wind/hydro (> 60 \$/MW-hr and $\leq$ 70 \$/MW-hr)
9					Competitive with combined cycle natural gas (> 50 \$/MW-hr and $\leq$ 60 \$/MW-hr)
10	Spent fuel removed from site	Sealed reactor vessel so very little LLW/ILW generated during operations	LLW/ILW with $T_{1/2}$ < 100 years and coolant/moderator does not require specialized treatment/stabilization, and high integrity fuel or reactor removed from site	No nuclear trained operators required (remote operation)	Competitive with geothermal ( $\leq$ 50 \$/MW-hr)

<sup>23</sup> The LCOE for each of the energy generation sources is taken from reference EIA August 2016, and is the estimated LCOE for new generation capacity. It is appropriate to compare the LCOE of SMNRs to new capacity of other potential energy generation sources since SMNRs are being considered for needed new capacity and/or for replacement of existing GHG-emitting capacity. The LCOE for the NuScale SMNR was developed using the same methodology as utilized for the other energy generation sources and is taken from reference IAEA August 2015b. While this metric was useful for making the high-level comparative assessment of the relative cost of the different SMNR concepts in this study, the reader is cautioned that this analysis should not be used to conclude that an SMNR technology is or is not economically competitive with other generation technologies. Actual plant investment decisions are affected by the specific technological and regional characteristics of a project, which involve numerous other factors not reflected in LCOE values. Furthermore, the LCOE values for the technologies presented in this table are estimates for utility-scale plants, not for small-scale plants of the type needed to support the Alberta applications discussed in this report. The NuScale LCOE, for example, is for a 12-module plant having an electrical capacity of 540 MW<sub>e</sub>.

### 8.3 Ranking Model Results

The ranking results for each reactor concept for both the “Full Compliance Ranking Model” and the “Full and Partial Compliance Ranking Model” are provided in Table 8.3-1 and compared graphically in Figure 8.3-1. The scores assigned to each of the SMNRs for each of the criteria are provided in Appendix B.

Generally, reactor concepts based on HTGR technology ranked the highest, which is to not unexpected since HTGRs operate at temperatures and pressures that readily support the generation of steam having sufficient quality for SAGD operation. HTGRs also score high on safety because 1) all of the concepts utilize a nearly fail-safe fuel technology that will not melt and release significant quantities of radiological materials under any accident conditions (i.e., essentially no exposure of the public to radiological materials) and 2) the coolant/moderator is not chemically reactive with air or water and so poses little occupational risk to workers. HTGR technology is also well developed and demonstrated, and generates less LLW/ILW compared to other reactor technologies (e.g., LWR technology).

An interesting outcome is that the HTGR concept by StarCore [Canada] ranked the highest for both ranking models (i.e., rank of > 0.74 by both models). While the StarCore SMNR concept scored very low on TRL and commercial deployment schedule, it scored very high on spent fuel management, adaptability to Alberta conditions, and plant decommissioning. This is because, according to StarCore 1) it provides all spent fuel management so that associated operator skills (i.e., refueling) and used fuel storage capability does not need to exist at the reactor site, 2) it provides remote operation and monitoring of the plant, and 3) as the owner-operator of the plant, it provides for plant decommissioning, including removal of the entire reactor, and associated used fuel, from the plant site every five years.

While many implementation details of the StarCore concept remain to be developed, or made publicly available, PNNL believes the following aspects of this concept pose difficult and likely unrealistic licensing and regulatory challenges for implementation by 2030: 1) remote monitoring and operation of the reactor at a centralized StarCore-operated facility, which poses a difficult licensing challenge due to cyber-security concerns that will have to be overcome, 2) licensing the RPV or reactor core module as a transportation container/package for used nuclear fuel, which will require the RPV/container to meet the licensing (including testing) requirements for used fuel transportation casks, 3) licensing the RPV or reactor core module as a transportation container/package for new nuclear fuel will require, likely via testing, that the RPV/internal components/new fuel meet stringent quality assurance requirements, following transportation to and installation at the reactor site and prior to operation, 4) away-from-reactor centralized used fuel storage facility<sup>24</sup> that will be available to receive and interim store the RPV/used fuel, and which will require its own license, and 5) making the reactor site completely accessible to the public with no overt security fences or guards, while still meeting strict physical security requirements, including robust physical defenses and a plant security force.

The HTR50S HTGR reactor by JAEA [Japan] also ranked very high for both ranking models (i.e., rank of > 0.69 by both models), however for somewhat different reasons than StarCore. This reactor concept scored very high on TRL because its design is based on the same design as has been deployed in an

---

<sup>24</sup> Currently, used nuclear fuel from Canada’s nuclear power reactors are maintained in interim storage facilities located at the nuclear reactor sites.

engineering scale test reactor in Japan since 1998. JAEA claims that no further technology development is needed and so the reactor concept is available now for deployment, although further design development is needed to support commercial deployment. JAEA however does not offer the same used fuel management, owner-operator, and decommissioning services as StarCore, and so scores lower on these criteria (as do most of the reactor concepts evaluated in this study).

No other HTGRs ranked  $> 0.6$  for the “Full Compliance Ranking” model. However, all of the other HTGRs ranked  $> 0.6$  for the “Full and Partial Compliance Ranking” model. Similar to the HTR50S reactor, each of these concepts scored fairly high on TRL and less than StarCore on the used fuel management, owner-operator, and decommissioning criteria. These reactor concepts also scored somewhat lower than StarCore and HTR50S because all but the Xe-100 are larger reactors that generate much more than the 11-18 MW<sub>e</sub> needed for SAGD operation and, in the case of the GT-HTR300, HTR-PM, and SC-HTGR reactors, each module generates over 200 MW<sub>e</sub>.

The only other reactor concept that ranked relatively high for both ranking models was the 4S sodium-cooled fast reactor by Toshiba. As with HTGRs, reactor concepts based on SFR technology score high on generating steam having sufficient quality for SAGD operation. Also, while SFRs score high generally on TRL because of significant practical experience with past and current deployed SFRs, the 4S scored very high based on completed and on-going testing in sodium-cooled experimental reactors. The 4S reactor also ranked relatively high based on its detailed design development being well advanced, the electricity of a single module being in the 11-18 MW<sub>e</sub> range needed for SAGD operation, and a very small operating crew because of a long refueling cycle that essentially eliminates the need for on-site nuclear operators trained in refueling operations and spent fuel management and because of the sealed reactor vessel that essentially only requires active monitoring and not active operation. SFRs generally and the 4S specifically scored lower on the safety and decommissioning criteria because of the use of liquid sodium metal as a coolant, which increases reactor operation and decommissioning complexity due to its high chemical reactivity with air/water.

All iPWRs were ranked from moderate to relatively low (i.e., rank of  $< 0.6$  by both models), with a rank  $> 0.5$  for the most promising and advanced designs. Several of the iPWR concepts ranked high for several of the criteria, such as TRL, commercial deployment by 2030, and safety criteria. Many of the iPWRs rank high in these areas because they 1) utilize existing PWR fuel technology that has extensive operational experience and therefore does not require additional fuel development or testing and 2) they employ advanced passive safety features that provide extended grace periods (relative to current deployed LWRs) of several days, and in some cases unlimited time periods<sup>25</sup>. However, all of the iPWRs ultimately ranked lower than the HTGRs and SFR discussed above because iPWR technology can not directly generate steam having sufficient quality for SAGD operation (i.e., the temperature and pressure of the steam produced in the secondary cooling loop are less than those required for SAGD operation)<sup>26</sup>.

---

<sup>25</sup> The term “grace period” is used to describe the ability of an NPP to remain in a safe condition for a substantial period of time after an incident or accident, without the need for human intervention, electric power, or additional coolant. The primary engineered features in iPWRs that provide for extended grace periods are 1) a large inventory of coolant and 2) natural circulation of the coolant, both of which serve to prevent the fuel from overheating, melting, and releasing large quantities of contaminated material.

<sup>26</sup> Steam having sufficient quality to support SAGD operation can be generated utilizing iPWRs if the energy produced is “upgraded” (i.e., steam pressure is increased). There are a number of options for upgrading the steam produced with iPWRs. One potential option is to incorporate a steam compressor into the balance-of-plant process to increase the temperature and pressure of the steam directly produced from the iPWR reactor. Another option is to

Other factors contributing to the lower ranking for iPWRs include 1) they generate more used nuclear fuel and require more frequent refueling (2-4 years), necessitating nuclear operators trained in refueling operations and used fuel management and 2) electricity generation capacity is generally much greater than 11-18 MW<sub>e</sub>.

The lowest ranked reactor concepts are those that use an HLMC coolant (i.e., liquid lead or LBE) or heavy-water coolant, none of which ranked > 0.6 on either of the ranking models. HLMC fast reactors require significant reactor and fuel technology development before they will be ready for commercial deployment, and do not directly generate steam having sufficient quality for SAGD operation. HWRs rank low because they also do not directly generate steam having sufficient quality for SAGD operation, and they require nuclear operators trained in refueling and used fuel management owing to their use of continuous at-power refueling operations. Also, HWRs have electricity generation capacities significantly greater than the 11-18 MW<sub>e</sub> required for SAGD operation.

---

use the electricity produced by an iPWR to power an electric boiler to produce SAGD quality steam. However, these options, or additional process steps, increase the cost of the iPWR technology for the SAGD application. Furthermore, both of these options require design and technology development to make them commercially available to support SAGD operation. For additional information, see SNC•Lavalin Nuclear May 2008 and ANS April 2014.

Table 8.3-1. Ranking Model Results

Reactor Type	Reactor Concept	Full Compliance Ranking	Full and Partial Compliance Ranking
iPWR	ACP100	0.48	0.49
	mPower	0.48	0.49
	CAREM-25	0.48	0.50
	FBNR	0.26	0.48
	SMR-160	0.41	0.43
	NuScale	0.48	0.56
	SMART	0.48	0.51
	Westinghouse SMR	0.48	0.42
HWR	AHWR300-LEU	0.35	0.42
	PHWR-220	0.34	0.37
HTGR	GT-HTR300	0.50	0.67
	GT-MHR	0.50	0.65
	HTR50S	0.69	0.74
	HTR-PM	0.59	0.64
	SC-HTGR	0.59	0.65
	StarCore	0.74	0.80
	Xe-100	0.59	0.61
MSR	IMSR	0.33	0.67
	TMSR-SF	0.38	0.58
	TMSR-LF	0.33	0.54
SFR	4S	0.60	0.77
	PGSFR	0.34	0.51
	PRISM	0.50	0.61
GFR	EM <sup>2</sup>	0.43	0.66
HLMC	G4M	0.36	0.58
	SVBR-100	0.26	0.47

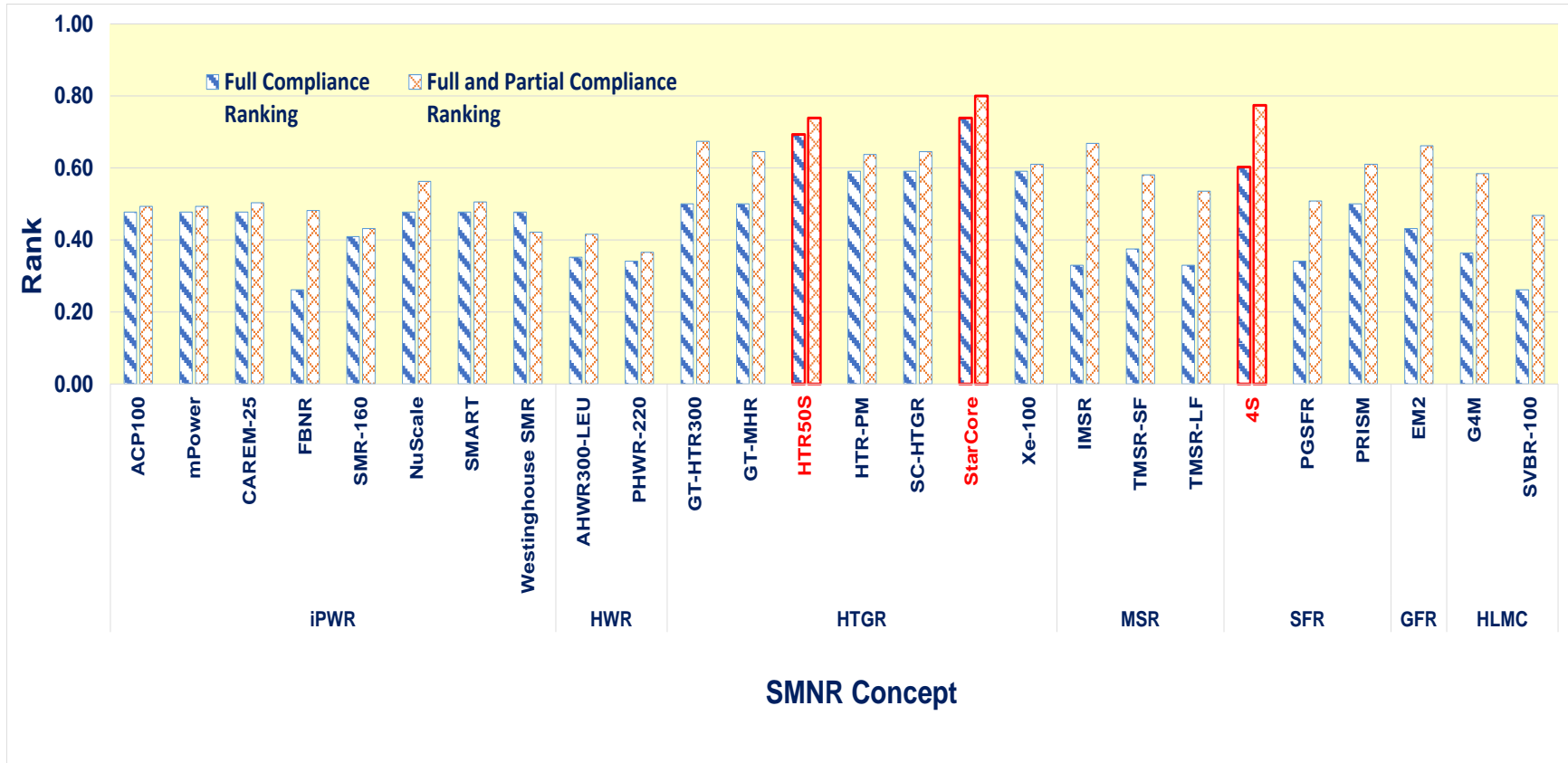

Figure 8.3-1. Comparison of SMNR Rankings

## 8.4 Sensitivity Cases

Three sensitivity cases were evaluated to assess the sensitivity of the Ranking Model results to the weights assigned to the criteria. Each case is discussed below.

### *Case 1: All Criteria are Weighted Equally*

In this sensitivity case, all of the weights assigned to each of the criteria were made the same (i.e., set equal to 10). The results are summarized in Table 8.4-1. The StarCore HTGR, HTR50S HTGR, and 4S SFR remain the highest scoring designs and in the same order as in the baseline case. The one exception is that the 4S SFR design is no longer highly ranked under the “Full Compliance Ranking Model,” and in this case other HTGRs take its place in the top rankings (i.e., HTR-PM, SC-HTGR, and Xe-100). This scoring system assumes that all of the criteria are of equal importance, and clearly shows that HTGR technology is the reactor technology that is most likely to be available to meet Alberta’s climate change goal of limiting GHG emissions from oils sands operations.

### *Case 2: Criteria Related to Issues that are Readily Resolvable are Removed*

In this sensitivity case, the weights assigned to Spent Fuel Management – Vendor Disposition and Alberta Adaptability are removed (i.e., set equal to 0). The results are summarized Table 8.4-2. The same three highest scoring reactor designs remain the top scoring designs, although their rankings changed. The HTR50S HTGR now has the highest rank, followed by the 4S SFR and StarCore HTGR, respectively. The HTR-PM HTGR also comes in as the 4th ranked reactor design having a rank  $\geq 0.7$ . This scoring system disregards criteria that address issues that are not technical discriminators, and continues to clearly show that HTGR technology is the reactor technology that is most likely to be available to meet Alberta’s climate change goal of limiting GHG emissions from oils sands operations.

### *Case 3: Criteria Not Directly Related to Alberta Goals are Removed; Remaining Criteria are Weighted Equally*

In this sensitivity case, the weights assigned to Safety, Spent Fuel Management, LLW/ILW Management, and Decommissioning are removed (i.e., set equal to 0). In addition, all of the weights assigned to each of the remaining criteria that are directly related to meeting the Alberta’s Climate Change Leadership Plan goals are made the same (i.e., set equal to 10). The results are summarized Table 8.4-3. The 4S SFR is now the highest ranked design and the HTR50S is the second highest ranked design. No other designs have a ranking  $> 0.7$ . This scoring system disregards criteria that are not directly related to meeting Alberta’s Climate Change Leadership Plan goals and assumes that all of the criteria that are directly related to meeting Alberta’s Climate Change Leadership Plan goals are of equal importance. As with the other cases, the results clearly show that HTGR technology is the reactor technology that is most likely to be available to meet Alberta’s climate change goal of limiting GHG emissions from oils sands operations.



Table 8.4-1. Sensitivity Case 1 Ranking Model Results

Reactor Type	Reactor Concept	Full Compliance Ranking	Full and Partial Compliance Ranking
iPWR	ACP100	0.54	0.53
	mPower	0.54	0.54
	CAREM-25	0.54	0.52
	FBNR	0.31	0.58
	SMR-160	0.46	0.48
	NuScale	0.54	0.59
	SMART	0.54	0.54
	Westinghouse SMR	0.54	0.48
HWR	AHWR300-LEU	0.38	0.45
	PHWR-220	0.38	0.40
HTGR	GT-HTR300	0.54	0.68
	GT-MHR	0.54	0.65
	HTR50S	0.69	0.72
	HTR-PM	0.62	0.63
	SC-HTGR	0.62	0.65
	StarCore	0.77	0.82
	Xe-100	0.62	0.60
MSR	IMSR	0.31	0.66
	TMSR-SF	0.38	0.58
	TMSR-LF	0.31	0.54
SFR	4S	0.54	0.72
	PGSFR	0.31	0.47
	PRISM	0.46	0.58
GFR	EM2	0.46	0.68
HLMC	G4M	0.46	0.66
	SVBR-100	0.31	0.51

Table 8.4-2. Sensitivity Case 2 Ranking Model Results

Reactor Type	Reactor Concept	Full Compliance Ranking	Full and Partial Compliance Ranking
iPWR	ACP100	0.56	0.49
	mPower	0.56	0.48
	CAREM-25	0.56	0.52
	FBNR	0.31	0.44
	SMR-160	0.48	0.41
	NuScale	0.56	0.57
	SMART	0.56	0.49
	Westinghouse SMR	0.56	0.40
HWR	AHWR300-LEU	0.41	0.44
	PHWR-220	0.40	0.40
HTGR	GT-HTR300	0.59	0.69
	GT-MHR	0.59	0.65
	HTR50S	0.81	0.77
	HTR-PM	0.69	0.70
	SC-HTGR	0.69	0.65
	StarCore	0.69	0.77
	Xe-100	0.69	0.67
MSR	IMSR	0.39	0.65
	TMSR-SF	0.44	0.63
	TMSR-LF	0.39	0.57
SFR	4S	0.71	0.78
	PGSFR	0.40	0.51
	PRISM	0.59	0.61
GFR	EM2	0.51	0.65
HLMC	G4M	0.37	0.52
	SVBR-100	0.31	0.43

Table 8.4-3. Sensitivity Case 3 Ranking Model Results

Reactor Type	Reactor Concept	Full Compliance Ranking	Full and Partial Compliance Ranking
iPWR	ACP100	0.43	0.51
	mPower	0.43	0.50
	CAREM-25	0.43	0.57
	FBNR	0.14	0.27
	SMR-160	0.29	0.31
	NuScale	0.43	0.54
	SMART	0.43	0.54
	Westinghouse SMR	0.43	0.37
HWR	AHWR300-LEU	0.29	0.40
	PHWR-220	0.43	0.43
HTGR	GT-HTR300	0.43	0.69
	GT-MHR	0.43	0.64
	HTR50S	0.71	0.79
	HTR-PM	0.57	0.67
	SC-HTGR	0.57	0.64
	StarCore	0.57	0.69
	Xe-100	0.57	0.61
MSR	IMSR	0.29	0.69
	TMSR-SF	0.29	0.57
	TMSR-LF	0.29	0.51
SFR	4S	0.71	0.84
	PGSFR	0.29	0.56
	PRISM	0.57	0.66
GFR	EM2	0.29	0.61
HLMC	G4M	0.14	0.44
	SVBR-100	0.14	0.46



## 9.0 Conclusions and Recommendations

The intent of this study was to provide a realistic assessment of the current state of development, and the potential for further development, of SMNRs and their prospective application in Alberta for 1) producing GHG emissions-free steam and electricity for extracting oil from Alberta oil sands, 2) producing non-intermittent, reliable, GHG emissions-free electricity in Alberta's deregulated electricity market, and 3) providing reliable, GHG emissions-free district heating, desalinated water, and electricity for rural communities. However, the results of the assessment documented in this report only evaluates the potential application of SMNRs to oil sands SAGD operation. Evaluations of the application of SMNRs to the other two applications, and to other applications in the oil sands industry (e.g., surface mining, bitumen upgrading) will likely yield different results and may be addressed in subsequent work.

Based on the results presented in the previous section of this report, the following are the conclusions and recommendations of the SMNR evaluation:

- The StarCore HTGR, HTR50S HTGR, and 4S FSR are the most likely or viable SMNR designs for meeting Alberta's climate change goal of limiting GHG emissions from oils sands operations. The StarCore HTGR is the highest ranked SMNR when accounting for all 13 of the criterion included in this assessment. The HTR50S HTGR and 4S FSR were in the top three ranking for all of the cases evaluated.
- All of the HTGR designs evaluated in this report are also potentially viable candidate SMNR designs for meeting Alberta's climate change goal of limiting GHG emissions from oil sands operations. In all of the cases evaluated, all of the HTGR designs evaluated in this assessment ranked high.
- A final down-select decision should only be made after careful consideration of the importance of each of the criteria used to rank each of the SMNR designs. Specifically, the weights assigned to each of the criteria should be based on input from a broader set of stakeholders, and the results of this assessment re-evaluated in light of the updated weights.
- Before a final down-select decision is made, it would be prudent to contact each of the developers/vendors of the top-ranked SMNR designs to substantiate some of the key assumptions made in this assessment (i.e, technology readiness levels, design development status, funding support, development schedules, etc.). Reliance solely on potentially out-dated publicly-available information, as was the case with this assessment, is likely to miss details important to the assessment.



## 10.0 References

AKME-Engineering, July 2015, "SVBR-100 Nuclear Technology as a Possible Option for Developing Countries," *World Journal of Nuclear Science and Technology*, Vol. 5, pp. 221-232, Scientific Research Publishing Inc., Irvine, CA ([http://file.scirp.org/pdf/WJNST\\_2015073109515218.pdf](http://file.scirp.org/pdf/WJNST_2015073109515218.pdf))

American Nuclear Society (ANS), May 2012, "PRISM: A Competitive Small Modular Sodium-Cooled Reactor," *Nuclear Technology*, Vol. 178, pp. 186-200, La Grange Park, Illinois ([http://gehitachiprism.com/wp-content/themes/geh\\_prism/resources/PRISM\\_Triplett\\_Loewen\\_Dooies.pdf](http://gehitachiprism.com/wp-content/themes/geh_prism/resources/PRISM_Triplett_Loewen_Dooies.pdf))

ANS, April 2014, "NuScale Energy Supply for Oil Recovery and Refining Applications," Proceedings of the International Congress on Advances in Nuclear Power Plants (ICAPP '14), April 6-9, 2014, Charlotte, North Carolina, USA ([http://www.nuscalepower.com/images/our\\_technology/nuscale-oil-refining-icapp14.pdf](http://www.nuscalepower.com/images/our_technology/nuscale-oil-refining-icapp14.pdf))

ANS, July 2014, "Changing the Game in Nuclear Energy," Presentation to the San Diego Section of the American Nuclear Society, July 23, 2014, LaGrange Park, IL, USA (<http://local.ans.org/sandiego/presentations/Schleicher.pdf>)

ANS, December 2014a, "The Steam Cycle High-Temperature Gas-Cooled Reactor," *Nuclear News*, Volume 57, Number 13, pp. 68-72, LaGrange Park, IL, USA

ANS, December 2014b, "The Integral Molten Salt Reactor," *Nuclear News*, Volume 57, Number 13, pp. 54-57, LaGrange Park, IL, USA

ANS, December 2014c, "EM<sup>2</sup>: A high-efficiency gas-cooled fast reactor," *Nuclear News*, Volume 57, Number 13, pp. 50-53, LaGrange Park, IL, USA

ANS, December 2014d, "PRISM: Redefining the relationship with plutonium," *Nuclear News*, Vol. 57, No. 13, pp. 64-66, La Grange Park, Illinois.

ANS, May 2015, "Can Nuclear Power and Renewables be Friends?" Proceedings of the International Congress on Advances in Nuclear Power Plants (ICAPP) 2015, May 3-6, 2015, Nice, France ([http://www.nuscalepower.com/images/our\\_technology/nuscale-integration-with-renewables\\_icapp15.pdf](http://www.nuscalepower.com/images/our_technology/nuscale-integration-with-renewables_icapp15.pdf)).

ANS, March 2016, "World List of Nuclear Power Plants," *Nuclear News*, Volume 59, Number 3, pp. 35-67, LaGrange Park, IL, USA

ANS, June 2016a, "Overall Reactor System Description of Prototype Gen-IV Sodium Cooled Fast Reactor," 2016 ANS Annual Meeting, held June 12-16, 2016 in New Orleans, LA, La Grange Park, IL, USA

ANS, June 2016b, "Overview of PGSFR Project," 2016 ANS Annual Meeting, held June 12-16, 2016 in New Orleans, LA, La Grange Park, IL, USA

ANS, July 2016, "PGSFR: An Advanced Fuel Cycle and Power Solution for Korea," ANS Nuclear Cafe, July 7, 2016 (<http://ansnuclearcafe.org/2016/07/07/pgsfr-an-advanced-fuel-cycle-and-power-solution-for-korea/#sthash.RNwbnlR1.dpbs>).

American Society of Mechanical Engineers (ASME), April 2014, "Integration of NuScale SMR with Desalination Technologies," Proceedings of the ASME 2014 Small Reactors Symposium, April 15-17, 2014, Washington, D.C. ([http://www.nuscalepower.com/images/our\\_technology/nuscale-desalination-asme-smr14.pdf](http://www.nuscalepower.com/images/our_technology/nuscale-desalination-asme-smr14.pdf)).

AREVA North America, March 2014, "AREVA HTGR Information Kit," Charlotte, NC, USA (<http://us.aveva.com/home/liblocal/docs/Nuclear/HTGR/HTGR-InfoKit-2014-03.pdf>).

Babcock & Wilcox (B&W), August 2010, Letter to NRC titled "B&W mPower™ Reactor Core Nuclear Design Codes and Methods Qualification Topical Report" (non-proprietary version), August 31, 2010, Charlotte, NC (<http://www.nrc.gov/docs/ML1024/ML102450302.pdf>).

BusinessKorea, January 7, 2016, "Localization of Nuke Fuel - 4th-gen Nuclear Reactor Fuel to be Developed by Korea," Seoul, Korea (<http://www.businesskorea.co.kr/english/news/sciencetech/13494-localization-nuke-fuel-4th-gen-nuclear-reactor-fuel-be-developed-korea>).

Canadian Nuclear Society (CNS), September 2006, "Performance Analysis of a Pb-Bi Cooled Fast Reactor - PEACER-300 in Proliferation Resistance and Transmutation Aspects," PHYSOR-2006 Conference, September 10-14, 2006 (<http://www.uxc.com/smr/Library%5CDesign%20Specific/PEACER/Papers/2006%20-%20Performance%20Analysis%20of%20a%20Pb-Bi%20Cooled%20Fast%20Reactor%20%E2%80%93%20PEACER-300%20in%20Proliferation%20Resistance%20and%20Transmutation%20Aspects.pdf>).

CNS, August 2014, "Pressurised Heavy Water Reactor (PHWR) Technology - It's relevance today," 19<sup>th</sup> Pacific Basin Nuclear Conference, August 24-28, 2014, Vancouver, BC, Canada ([http://pbnc2014.org/plan\\_present/Banerjee\\_WBLewisLecture\\_2014Aug25\\_PBNC2014\\_final.pdf](http://pbnc2014.org/plan_present/Banerjee_WBLewisLecture_2014Aug25_PBNC2014_final.pdf)).

Chinese Academy of Science (CAS) Thorium Molten Salt Reactor (TMSR) Center of Excellence, October 2015, "Status of the TMSR-SF1 Licensing Efforts," MSR - 2015 Workshop on Molten Salt Reactor Technologies, October 15-16, 2015, Oak Ridge, TN, USA ([https://public.ornl.gov/conferences/MSR2015/pdf/9ORNL-workshop-20151016\\_KunChen.pdf](https://public.ornl.gov/conferences/MSR2015/pdf/9ORNL-workshop-20151016_KunChen.pdf)).

Elsevier Ltd., 2011, "Advanced Nuclear Reactor Systems - An Indian Perspective," *Energy Procedia*, Vol. 7, pg. 34-50 ([http://ac.els-cdn.com/S1876610211015141/1-s2.0-S1876610211015141-main.pdf?\\_tid=df945a10-3f0e-11e6-ae99-00000aab0f6b&acdnat=1467324559\\_e465a6588c0ca2217cc4656cdd49a2dc](http://ac.els-cdn.com/S1876610211015141/1-s2.0-S1876610211015141-main.pdf?_tid=df945a10-3f0e-11e6-ae99-00000aab0f6b&acdnat=1467324559_e465a6588c0ca2217cc4656cdd49a2dc)).

Elsevier Ltd., June 2013, "A Small Modular Reactor Design for Multiple Energy Applications: HTR50S," *Nuclear Engineering and Technology*, Vol. 45, No. 3, pp. 401-414 (<http://www.sciencedirect.com/science/article/pii/S1738573315300267>).

Elsevier Ltd., October 2013, "Licensing small modular reactors," *Energy*, Vol. 61, pg. 555-564 (<http://www.princeton.edu/~ramana/EGY5388-SMR-Licensing-2013.pdf>).



Elsevier Ltd., August 2016, "Overall System Description and Safety Characteristics of Prototype Gen IV Sodium Cooled Fast Reactor in Korea," *Nuclear Engineering and Technology* (<http://www.sciencedirect.com/science/article/pii/S1738573315300267>).

GE Hitachi Nuclear Energy, date unknown (extracted September 9, 2016), "GE Hitachi Nuclear Energy PRISM Technical Brief," (<http://www.uxc.com/smr/Library%5CDesign%20Specific/PRISM/Other%20Documents/Technical%20Brief.pdf>).

GE Hitachi Nuclear Energy International, LLC, June 7, 2016, "PRISM & U.S. Licensing," Washington, D.C. (<http://www.nrc.gov/public-involve/conference-symposia/adv-rx-non-lwr-ws/2016/21-loewen-prism.pdf>).

General Atomics (GA), March 2015, "EM<sup>2</sup>: A Compact Gas-Cooled Fast Reactor for the 21st Century," March 24, 2-15, San Diego, CA, USA ([http://radchem.nevada.edu/classes/rfss/lectures/EM2%20Reactor%20Dev%20at%20GA\\_Schleicher\\_UNLV%20Summer%20School%20Visit%20\(2015\).pdf](http://radchem.nevada.edu/classes/rfss/lectures/EM2%20Reactor%20Dev%20at%20GA_Schleicher_UNLV%20Summer%20School%20Visit%20(2015).pdf)).

Global Trade Media, October 2012, "A steam cycle HTGR," *Nuclear Engineering International*, pp. 29-33, Kent, UK ([http://www.aveva.com/globaloffer/liblocal/docs/EnergyBusiness/EnergyBusiness-eNewsletter9/A\\_steam\\_cycle\\_HTGR\\_NuclearEngineeringInternational%E2%80%93October2012.pdf](http://www.aveva.com/globaloffer/liblocal/docs/EnergyBusiness/EnergyBusiness-eNewsletter9/A_steam_cycle_HTGR_NuclearEngineeringInternational%E2%80%93October2012.pdf)).

Hatch Ltd., June 2016, "SMR Deployment Feasibility Study – Feasibility of the Potential Deployment of Small Modular Reactors (SMRs) in Ontario," Report No. H350381-00000-162-066-0001, Rev. 0, prepared for the Ontario Ministry of Energy ([http://ontarioenergyreport.ca/pdfs/MOE%20-%20Feasibility%20Study\\_SMRs%20-%20June%202016.pdf](http://ontarioenergyreport.ca/pdfs/MOE%20-%20Feasibility%20Study_SMRs%20-%20June%202016.pdf)).

Hindawi Publishing Corporation, November 2013, "A Small-Sized HTGR System Design for Multiple Heat Applications for Developing Countries," *International Journal of Nuclear Energy*, Vol. 2013, (<https://www.hindawi.com/archive/2013/918567/>).

Holtec International, May 2015, "Holtec Technical Bulletin - Essentials of SMR-160 Small Modular Reactor," Rev. 9, May 14, 2015 (<https://smrllc.files.wordpress.com/2015/06/htb-015-hi-smur-rev3.pdf>).

Holtec International, January 2014, letter to USNRC Document Control Desk, Subject: "Holtec International Voluntary Response to Regulatory Issue Summary (RIS) 2013-18, 'Licensing Submittal Information and Design Development Activities for Small Modular Reactor Designs,'" January 30, 2014, ADAMS Accession Number ML14036A136 (<https://adamswebsearch2.nrc.gov/webSearch2/main.jsp?AccessionNumber=ML14036A136>).

International Atomic Energy Agency (IAEA), December 2007, "Liquid Metal Cooled Reactors: Experience in Design and Operation," IAEA-TECDOC-1569, Vienna, Austria ([http://www-pub.iaea.org/MTCD/Publications/PDF/te\\_1569\\_web.pdf](http://www-pub.iaea.org/MTCD/Publications/PDF/te_1569_web.pdf)).

IAEA, October 2009a, "CAREM Prototype Construction and Licensing Status," IAEA-CN-164-5S01, International Conference on Opportunities and Challenges for Water Cooled Reactors in the 21st Century, 27-30 October 2009, Vienna, Austria ([http://www-pub.iaea.org/MTCD/publications/PDF/P1500\\_CD\\_Web/htm/pdf/topic5/5S01\\_D.%20Delmastro.pdf](http://www-pub.iaea.org/MTCD/publications/PDF/P1500_CD_Web/htm/pdf/topic5/5S01_D.%20Delmastro.pdf)).

IAEA, October 2009b, "Water Cooled FBNR Nuclear Reactor," IAEA-CN-164-5S05, "International Conference on Opportunities and Challenges for Water Cooled Reactors in the 21st Century," 27-30 October 2009, Vienna, Austria ([http://www-pub.iaea.org/MTCD/publications/PDF/P1500\\_CD\\_Web/htm/pdf/topic5/5S05\\_F.%20Sefidvash.pdf](http://www-pub.iaea.org/MTCD/publications/PDF/P1500_CD_Web/htm/pdf/topic5/5S05_F.%20Sefidvash.pdf)).

IAEA, January 2011, "Status Report 72 - Fixed Bed Nuclear Reactor (FBNR)," Advanced Reactor Information System (ARIS) (<https://aris.iaea.org/PDF/FBNR.pdf>).

IAEA, April 2011, "Status report 74 - Indian 220 MWe PHWR (IPHWR-220)," Vienna, Austria (<https://aris.iaea.org/sites/..%5CPDF%5CIPHWR-220.pdf>).

IAEA, July 2011a, "Design, Safety & Operability performances of 220 MWe, 540 MWe & 700 MWe PHWRs in India," Inter-regional workshop on Advanced Nuclear Reactor Technology for Near Term Deployment, July 4-8, 2011, Vienna, Austria ([https://www.iaea.org/NuclearPower/Downloads/Technology/meetings/2011-Jul-4-8-ANRT-WS/2\\_INDIA\\_PHWR\\_NPCIL\\_Muktibodh.pdf](https://www.iaea.org/NuclearPower/Downloads/Technology/meetings/2011-Jul-4-8-ANRT-WS/2_INDIA_PHWR_NPCIL_Muktibodh.pdf)).

IAEA, July 2011b, "Status report 101 - Gas Turbine High Temperature Reactor (GTHTR300C)," Vienna, Austria (<https://aris.iaea.org/sites/..%5CPDF%5CGTHTR300C.pdf>).

IAEA, July 2011c, "Status of Development and Deployment Scheme of HTR-PM in the People's Republic of China," Inter-regional workshop on Advanced Nuclear Reactor Technology for Near Term Deployment, July 4-8, 2011, Vienna, Austria ([https://www.iaea.org/NuclearPower/Downloads/Technology/meetings/2011-Jul-4-8-ANRT-WS/5\\_CHINA\\_HTR-PM\\_TsinghuaU\\_Dong.pdf](https://www.iaea.org/NuclearPower/Downloads/Technology/meetings/2011-Jul-4-8-ANRT-WS/5_CHINA_HTR-PM_TsinghuaU_Dong.pdf)).

IAEA, July 2011d, "SVBR-100: New Generation Power Plants for Small and Medium-Sized Power Applications," Interregional Workshop on Advanced Nuclear Reactor Technology, July 4-8, 2011, Vienna, Austria ([https://www.iaea.org/NuclearPower/Downloadable/Meetings/2011/2011-07-04-07-08-WS-NPTD/2\\_RUSSIA\\_SVBR\\_AKME-eng\\_Antysheva.pdf](https://www.iaea.org/NuclearPower/Downloadable/Meetings/2011/2011-07-04-07-08-WS-NPTD/2_RUSSIA_SVBR_AKME-eng_Antysheva.pdf)).

IAEA, October 2011, "Status report 96 - High Temperature Gas Cooled Reactor - Pebble-Bed Module (HTR-PM)," Vienna, Austria (<https://aris.iaea.org/sites/..%5CPDF%5CHTR-PM.pdf>).

IAEA, 2012, "Status of Fast Reactor Research and Technology Development," IAEA-TECDOC-1691, Vienna, Austria (<https://www.iaea.org/NuclearPower/Downloadable/FR/tecdoc-1691-status-of-fr-research-published.pdf>).

IAEA, July 2012a, "Re-evaluation of Maximum Fuel Temperature of the HTTR at Normal Operation," IAEA Technical Meeting on Re-evaluation of Maximum Operating Temperatures and Accident Conditions for High Temperature Reactor Fuel and Structural Materials, July 10-12, 2012, Vienna, Austria ([https://www.iaea.org/NuclearPower/Downloadable/Meetings/2012/2012-07-10-07-12-TM-NPTD/7\\_fueltemphtrr.pdf](https://www.iaea.org/NuclearPower/Downloadable/Meetings/2012/2012-07-10-07-12-TM-NPTD/7_fueltemphtrr.pdf)).

IAEA, July 2012b, "Overview of JAEA's Research Activity on HTGR," IAEA Technical Meeting on Re-evaluation of Maximum Operating Temperatures and Accident Conditions for High Temperature Reactor Fuel and Structural Materials, July 10-12, 2012, Vienna, Austria

[https://www.iaea.org/NuclearPower/Downloadable/Meetings/2012/2012-07-10-07-12-TM-NPTD/3\\_japan.pdf](https://www.iaea.org/NuclearPower/Downloadable/Meetings/2012/2012-07-10-07-12-TM-NPTD/3_japan.pdf)).

IAEA, July 2012c, "Safety consideration in HTR-PM," IAEA Technical Meeting on Re-evaluation of Maximum Operating Temperatures and Accident Conditions for High Temperature Reactor Fuel and Structural Materials, Vienna, Austria

[https://www.iaea.org/NuclearPower/Downloadable/Meetings/2012/2012-07-10-07-12-TM-NPTD/10\\_sc.pdf](https://www.iaea.org/NuclearPower/Downloadable/Meetings/2012/2012-07-10-07-12-TM-NPTD/10_sc.pdf)).

IAEA, September 2012, "Status of Small and Medium Sized Reactor Designs, A Supplement to the IAEA Advanced Reactors Information System (ARIS)," Vienna, Austria

<https://www.iaea.org/NuclearPower/Downloadable/SMR/files/smr-status-sep-2012.pdf>).

IAEA, February 2013, "Safety Approach of PGSFR in Korea," The 3rd Joint GIF-IAEA Workshop on Safety Design Criteria for SFRs, February 26-27, 2013, Vienna, Austria

<https://www.iaea.org/NuclearPower/Downloadable/Meetings/2013/2013-02-26-02-27-TM-SFR/day-2/7-Jeong-RoK.pdf>).

IAEA, March 2013a, "Super-safe, Small and Simple Reactor (4S, Toshiba Design)," IAEA Advanced Reactor Information System (ARIS), Vienna, Austria (<https://aris.iaea.org/sites/..%5CPDF%5C4S.pdf>).

IAEA, March 2013b, "Operating experience from the BN600 sodium fast reactor," Proceedings of International Conference on Fast Reactors and Related Fuel Cycles: Safe Technologies and Sustainable Scenarios (FR13), March 4-7, 2013, Vienna, Austria

<https://www.iaea.org/NuclearPower/Downloadable/Meetings/2013/2013-03-04-03-07-CF-NPTD/T9.1/T9.1.potapov.pdf>).

IAEA, June 2013, "Small Reactors R&D in China," Technical Working Groups on Advanced Technologies for LWRs and HWRs (TWG-LWR and TWG-HWR), June 18-20, 2013, Vienna, Austria

<https://www.iaea.org/NuclearPower/Downloadable/Meetings/2013/2013-06-18-06-20-TWG-NPTD/36-snerdi-china-smr.pdf>).

IAEA, September 2013, "Progress of ACP100," Technical Meeting on Small and Medium sized Reactors Technology Development for Near term Deployment," September 2-4, 2013, Chengdu, China

[https://www.iaea.org/NuclearPower/Downloadable/Meetings/2013/2013-09-02-09-04-TM-NPTD/2\\_china\\_song\\_acp100.pdf](https://www.iaea.org/NuclearPower/Downloadable/Meetings/2013/2013-09-02-09-04-TM-NPTD/2_china_song_acp100.pdf)).

IAEA, October 2013, "Status of Innovative Fast Reactor Designs and Concepts, A Supplement to the IAEA Advanced Reactors Information System (ARIS)," Vienna, Austria

<https://www.iaea.org/NuclearPower/Downloadable/FR/booklet-fr-2013.pdf>).

IAEA, November 2013, "Advanced Heavy Water Reactor (AHWR)," Vienna, Austria

<https://aris.iaea.org/sites/..%5CPDF%5CAHWR.pdf>).

IAEA, September 2014, "Advances in Small Modular Reactor Technology Developments, A Supplement to: IAEA Advanced Reactors Information System (ARIS)," Vienna, Austria

[https://www.iaea.org/NuclearPower/Downloadable/SMR/files/IAEA\\_SMR\\_Booklet\\_2014.pdf](https://www.iaea.org/NuclearPower/Downloadable/SMR/files/IAEA_SMR_Booklet_2014.pdf)).

IAEA, February 2015, "Status of Gas Cooled Reactor Programs in Russian Federation," Meeting of the Technical Working Group on Gas Cooled Reactors (TWG-GCR), February 25-27, 2015, Vienna, Austria ([https://www.iaea.org/NuclearPower/Downloadable/Meetings/2015/2015-02-25-02-27-NPTDS/Day1/07-Fomichenko\\_Status\\_and\\_Prospects\\_of\\_HTGR.pdf](https://www.iaea.org/NuclearPower/Downloadable/Meetings/2015/2015-02-25-02-27-NPTDS/Day1/07-Fomichenko_Status_and_Prospects_of_HTGR.pdf)).

IAEA, August 2015a, "ACP100 Technical & Economic Aspects," Technical Meeting on the Economic Analysis of High Temperature Gas Cooled Reactors and Small and Medium Sized Reactors, August 25-28, 2015, Vienna, Austria ([https://www.iaea.org/NuclearPower/Downloadable/Meetings/2015/2015-08-25-08-28-NPTDS/DAY2/2\\_ACP100\\_technical\\_and\\_economic\\_aspects.pdf](https://www.iaea.org/NuclearPower/Downloadable/Meetings/2015/2015-08-25-08-28-NPTDS/DAY2/2_ACP100_technical_and_economic_aspects.pdf)).

IAEA, August 2015b, "NuScale Technology & Economic Overview - Simple, Safe, Economic," Technical Meeting on the Economic Analysis of High Temperature Gas Cooled Reactors and Small and Medium Sized Reactors, August 25-28, 2015, Vienna, Austria ([https://www.iaea.org/NuclearPower/Downloadable/Meetings/2015/2015-08-25-08-28-NPTDS/DAY2/1\\_NuScale\\_Power\\_SMR\\_-\\_Simple,\\_Safe,\\_Economic.pdf](https://www.iaea.org/NuclearPower/Downloadable/Meetings/2015/2015-08-25-08-28-NPTDS/DAY2/1_NuScale_Power_SMR_-_Simple,_Safe,_Economic.pdf)).

IAEA, August 2015c, "Technologies of HTR-PM Plant and its economic potential," IAEA Technical Meeting on the Economic Analysis of High Temperature Gas Cooled Reactors and Small and Medium Sized Reactors, August 25-28, 2015 ([https://www.iaea.org/NuclearPower/Downloadable/Meetings/2015/2015-08-25-08-28-NPTDS/DAY1/5\\_DONG\\_Y-201508V2.pdf](https://www.iaea.org/NuclearPower/Downloadable/Meetings/2015/2015-08-25-08-28-NPTDS/DAY1/5_DONG_Y-201508V2.pdf)).

IAEA, August 2015c, "JAEA latest reactor design (GTHTR300) and its economic analysis," Technical Meeting on the Economic Analysis of High Temperature Gas Cooled Reactors and Small and Medium Sized Reactors, August 25-28, 2015, Vienna, Austria ([https://www.iaea.org/NuclearPower/Downloadable/Meetings/2015/2015-08-25-08-28-NPTDS/DAY1/6\\_JAEA\\_latest\\_reactor\\_design\\_\(GTHTR300\)\\_and\\_its\\_economic\\_analysis.pdf](https://www.iaea.org/NuclearPower/Downloadable/Meetings/2015/2015-08-25-08-28-NPTDS/DAY1/6_JAEA_latest_reactor_design_(GTHTR300)_and_its_economic_analysis.pdf)).

IAEA, October 2015, "HTGR Plant Design," Training Course on High Temperature Gas-cooled Reactor Technology, October 12-23, 2015, Serpong, Indonesia ([https://www.iaea.org/NuclearPower/Downloadable/Meetings/2015/2015-10-19-10-23/DOC/G3\\_HTGR\\_Plant\\_Design\\_20151015.pdf](https://www.iaea.org/NuclearPower/Downloadable/Meetings/2015/2015-10-19-10-23/DOC/G3_HTGR_Plant_Design_20151015.pdf)).

Idaho National Laboratory (INL), September 2010, "High Temperature Gas-Cooled Reactors Lessons Learned Applicable to the Next Generation Nuclear Plant," INL/EXT-10-19329, Idaho Falls, ID, USA (<https://inldigitallibrary.inl.gov/sti/4655299.pdf>).

INL, April 2011a, "High Temperature Gas-Cooled Reactors Lessons Learned Applicable to Next Generation Nuclear Plant," INL/EXT-10-19329, Revision 1, Idaho Falls, ID, USA (<https://inldigitallibrary.inl.gov/sti/5026001.pdf>).

INL, April 2011b, "Process Heat Exchanger Options for Fluoride Salt High Temperature Reactor," INL/EXT-11-21584, Idaho Falls, Idaho, USA (<https://inldigitallibrary.inl.gov/sti/4953400.pdf>).

INL and PTAC, October 2011, "Integration of High Temperature Gas-cooled Reactor Technology with Oil Sands Processes," INL/EXT-11-23239, Next Generation Nuclear Plant Project, Idaho Falls, Idaho.

INL, November 2014, "NRC Licensing Status Summary Report for NGNP," INL/EXT-13-28205, Revision 1, Idaho Falls, Idaho, USA (<https://inldigitallibrary.inl.gov/sti/6618416.pdf>).

INL, January 2016, "High Temperature Gas-Cooled Reactor Point Design: Summary Report," INL/EXT-16-37661, Idaho Falls, ID, USA (<https://inldigitallibrary.inl.gov/sti/6748415.pdf>).

International Journal of Scientific & Engineering Research, February 2012, "Accident Analysis of Narora Fire Accident," Volume 3, Issue 2  
(<http://citeseerx.ist.psu.edu/viewdoc/download?doi=10.1.1.302.618&rep=rep1&type=pdf>).

International Panel on Fissile Materials, February 2010, "Fast Breeder Reactor Programs: History and Status," (<http://fissilematerials.org/library/rr08.pdf>).

Kyoto University, December 2014, "PEACER-300: TRU burner," Proceedings of 12th International Workshop on Asian Networks for Accelerator-Driven System and Nuclear Transmutation Technology (ADS+NTT 2014), December 15-16, 2014, Hefei, China ([http://www.rri.kyoto-u.ac.jp/CAD/workshop2/ADS-NTT2014\\_20150105.pdf](http://www.rri.kyoto-u.ac.jp/CAD/workshop2/ADS-NTT2014_20150105.pdf)).

Latin American Section American Nuclear Society (LAS/ANS), July 2014, "Adopted licensing scheme for an Argentinean modular reactor," LAS/ANS 2014 Symposium "Small Modular Reactors for Nuclear Power," July 21-24, 2014, Rio de Janeiro, Brazil (<http://las-ans.org.br/PDF2014/Panel%205%20-%20Alejandro%20Lazarte%20-%20July22%201600-1730.pdf>).

Massachusetts Institute of Technology (MIT), 2005, "Nuclear Technology & Canadian Oil Sands: Integration of Nuclear Power with In-Situ Oil Extraction," Cambridge, MA.

MIT, January 12, 2016, "Advanced Nuclear Startup Terrestrial Energy Lands Initial Funding," *MIT Technology Review*, Cambridge, MA, USA (<https://www.technologyreview.com/s/545406/advanced-nuclear-startup-terrestrial-energy-lands-initial-funding/>).

MPR Associates Inc., March 2009, "Evaluation of High Temperature Reactors for Potential Application to Thermal In-Situ Recovery of Oil Sands," Report MPR-3254 prepared for Petroleum Technology Alliance Canada, Calgary, Alberta, Canada.

Next Generation Nuclear Plant (NGNP) Industry Alliance Limited, June 2013, "High Temperature Gas-Cooled Reactor (HTGR) Technology," Presentation to The Governor's Nuclear Advisory Council, June 13, 2013, ([https://www.admin.sc.gov/files/nac/NGNP\\_HTGR\\_Technology.pdf](https://www.admin.sc.gov/files/nac/NGNP_HTGR_Technology.pdf)).

NGNP Industry Alliance Limited, June 2015, "A Business Plan for High-Temperature Gas-Cooled Reactor (HTGR) Commercialization," Ridgeland, MS, USA  
(<http://www.ngnpalliance.org/index.php/contact>).

NGNP Industry Alliance Limited, August 2015, "Status of the NGNP Industrial Alliance work and the business plan economics," IAEA Technical Meeting, August 25-28, 2015, Vienna, Austria  
(<http://www.ngnpalliance.org/index.php/resources>).

NGNP Industry Alliance Limited, March 2016, "NGNP Industry Alliance and the Opportunity for an International Initiative for Deployment of a Modern Prismatic Block HTGR," Summary and Presentations

from the First Organizational Meeting International Prismatic Block HTGR Commercial Deployment, March 8-10, 2016, Washington, D.C., USA (<http://www.ngnpalliance.org/index.php/resources>).

Nuclear Energy Insider, April 2016, "NuScale Supply Chain," 6th Annual International SMR and Advanced Reactor Summit, April 14-15, 2016, Atlanta, GA.

Nuclear Energy Institute (NEI), January 2013, "B&W mPower Small Modular Reactor - Creating the future of nuclear power," NEI Nuclear Fuel Supply Forum, January 30, 2013, Washington, D.C. (<http://www.nei.org/corporatesite/media/filefolder/ferraranfsfjan2013.pdf?ext=.pdf>).

Nuclear Plant Journal, May-June 2014, "HTGR Reactor," Downers Grove, IL, USA (<http://digitaleditions.nuclearplantjournal.com/MJ14/files/assets/common/downloads/page0028.pdf>).

NuScale Power, LLC, May 2016, "NuScale Power Update - Blazing the Trail to the Future of Nuclear Energy," Partners in Science and Technology Up 'n Atom Breakfast, May 3, 2016 (<http://stoppingclimatechange.com/NuScale%20-%20McGough%20Up%20n%20Atom%20050316.pdf>).

Oak Ridge National Laboratory (ORNL), April 1980, "Descriptions of Selected Accidents that have Occurred at Nuclear Reactor Facilities," ORNL/NSIC-176, Oak Ridge, TN, USA (<http://www.nucleartourist.com/references/Descriptions%20of%20Selected%20Nuclear%20Reactor%20Accidents.pdf>).

ORNL, September 2002, "TRISO-Coated Fuel Processing to Support High-Temperature Gas-Cooled Reactors," ORNL/TM-2002/156, Oak Ridge, TN, USA (<http://web.ornl.gov/~webworks/cpnr/y2003/rpt/114586.pdf>).

ORNL, November 2009, "Safeguards Challenges for Pebble-Bed Reactors Designed by People's Republic of China," ORNL/TM-2008/229, Oak Ridge, TN, USA, (<http://info.ornl.gov/sites/publications/files/Pub13759.pdf>).

ORNL, May 2014, "Overview of Modular HTGR Safety Characterization and Postulated Accident Behavior Licensing Strategy," ORNL/TM-2014/187, Oak Ridge, TN, USA (<http://info.ornl.gov/sites/publications/files/Pub49707.pdf>).

Organization for Economic Development (OECD), January 2014, "Technology Roadmap Update for Generation IV Nuclear Energy Systems," Issued by the OECD Nuclear Energy Agency for the GEN IV International Forum<sup>SM</sup>, Paris, France (<https://www.gen-4.org/gif/upload/docs/application/pdf/2014-03/gif-tru2014.pdf>).

Pacific Northwest National Laboratory (PNNL), October 2011, "High Temperature Gas Reactors: Assessment of Applicable Codes and Standards," PNNL-20869, Richland, WA ([http://www.pnnl.gov/main/publications/external/technical\\_reports/PNNL-20869.pdf](http://www.pnnl.gov/main/publications/external/technical_reports/PNNL-20869.pdf)).

PennWell Corporation, February 5, 2015, "The Promise of Small Modular Reactors," Power Engineering, (<http://www.power-eng.com/articles/npi/print/volume-8/issue-1/nucleus/the-promise-of-small-modular-reactors.html>).



Platts, May 2013, "SMR-160: The Gravity-Driven and Gravity-Protected, Subterranean Small Modular Reactor," 4th Annual Small Modular Reactors Conference - Managing the Technical, Cost, and Regulatory CHallenges to Develop a New Nuclear Industry, May 29-30, 2013, Washington, D.C. ([http://www.platts.com/IM.Platts.Content/ProductsServices/ConferenceandEvents/2013/pc330/presentations/Kris\\_Singh.pdf](http://www.platts.com/IM.Platts.Content/ProductsServices/ConferenceandEvents/2013/pc330/presentations/Kris_Singh.pdf)).

Research Association of High Temperature Gas Cooled Reactor Plant (RAHP), March 2013, "RAHP News Letter No. 12," Tokyo, Japan ([https://www.iae.or.jp/htgr/pdf/05\\_newsletter/05\\_2/05\\_2\\_rahp\\_No12\\_201303\\_r.pdf](https://www.iae.or.jp/htgr/pdf/05_newsletter/05_2/05_2_rahp_No12_201303_r.pdf)).

Research & Development (R&D) Caucus, 2012, "B&W mPower Small Modular Reactor - Creating the future of nuclear power," (<http://researchcaucus.org/wp-content/uploads/2015/12/Helin-BW-mPower-Presentation.pdf>).

Sandia National Laboratory (SNL), January 2015, "Nuclear Security Governance in India: Institutions, Instruments, and Culture," SAND2015-0233, Albuquerque, NM (<http://www.sandia.gov/cooperative-monitoring-center/assets/documents/sand2015-0233.pdf>).

Shanghai Institute of Applied Physics (SINAP), October 2015, "China's TMSR programme," MSR - 2015 Workshop on Molten Salt Reactor Technologies, October 15-16, 2015, Oak Ridge, TN, USA ([https://public.ornl.gov/conferences/MSR2015/pdf/10-China's%20TMSR%20programm\\_HongjieXu.%20pptx.pdf](https://public.ornl.gov/conferences/MSR2015/pdf/10-China's%20TMSR%20programm_HongjieXu.%20pptx.pdf)).

SINAP, October 27, 2015, "TMSR Project in China," TMSR Center, Shanghai, China (<http://tcw15.mit.edu/sites/default/files/documents/TMSRstatus-liuwei.pdf>).

SNC•Lavalin Nuclear, Inc., May 2008, "Nuclear Energy Options Evaluation Report," Document Number 017759-0000-45RA-0001, Oil Sands Phase 1 Energy Options Feasibility Study.

University of Texas at Austin, August 2010, "A Real Options Analysis and Comparative Cost Assessment of Nuclear and Natural Gas Applications in the Athabasca Oil Sands," Thesis by Julia Blum Harvey, B.A., Austin, Texas.

Southern States Energy Board (SSEB), August 2012, "SMR-160 Unconditionally Safe & Economical Green Energy Technology for the 21st Century," 2012 Associate Members Meeting, 10 August 2012 (<http://www.sseb.org/downloads/AssociateMem-2012/PR/oneid.pdf>).

StarCore Nuclear, extracted from website on July 15, 2016 (<http://starcorenuclear.ca/#!/welcome/>).

Terrestrial Energy Inc., March 2015, "The Integral Molten Salt Reactor," Molten Salt Reactor Workshop, April 17, 2015, Delft University ([http://www.janleenkloosterman.nl/reports/kivi\\_leblanc\\_20150417.pdf](http://www.janleenkloosterman.nl/reports/kivi_leblanc_20150417.pdf)).

Terrestrial Energy Inc., October 2015, "The Integral Molten Salt Reactor," MSR - 2015 Workshop on Molten Salt Reactor Technologies, October 15-16, 2015, Oak Ridge, TN, USA (<https://public.ornl.gov/conferences/MSR2015/pdf/ORNL%20MSRE%20workshop%20Oct2015UPDATED%20ex%20Confi.pdf>).

Terrestrial Energy Inc., March 4, 2016, "Terrestrial Energy Awarded \$5.7 Million Grant from Canadian Federal Regulator," Oakville, ON, Canada (<http://terrestrialenergy.com/terrestrial-energy-awarded-5-7-million-grant-from-canadian-federal-government/>).

The Standing Senate Committee on Energy, the Environment and Natural Resources, June 2001, "Canada's Nuclear Reactors: How Much Safety is Enough?" (<http://www.parl.gc.ca/Content/SEN/Committee/371/enrg/rep/repintjun01-e.htm>).

Thorium Molten Salt Reactor (TMSR) Center of Chinese Academy of Science (CAS), October 2013, "Thorium Energy R&D in China," Shanghai, China ([http://www.thoriumenergyworld.com/uploads/6/9/8/7/69878937/thorium\\_energy\\_r\\_and\\_d\\_in\\_china\\_-\\_hongjie\\_xu\\_-\\_tmsr\\_-\\_thec13.pdf](http://www.thoriumenergyworld.com/uploads/6/9/8/7/69878937/thorium_energy_r_and_d_in_china_-_hongjie_xu_-_tmsr_-_thec13.pdf)).

U.S. Department of Energy (DOE) and Nuclear Regulatory Commission (NRC), June 2016, "Advanced Reactor Fuel Challenges for EM<sup>2</sup>," DOE-NRC Second Workshop on Advanced Non-LWR Reactors, June 7-8, 2016, Rockville, MD, USA (<http://www.nrc.gov/public-involve/conference-symposia/adv-rx-non-lwr-ws/2016/24-back-adv-rx-fuel-challenges-for-em2.pdf>).

U.S. Energy Information Agency (EIA), August 2016, "Levelized Cost and Levelized Avoided Cost of New Generation Resources in the Annual Energy Outlook 2016," Washington, D.C. USA ([https://www.eia.gov/forecasts/aeo/pdf/electricity\\_generation.pdf](https://www.eia.gov/forecasts/aeo/pdf/electricity_generation.pdf)).

U.S. Nuclear Regulatory Commission (NRC), September 2010, "Status of the Accident Sequence Precursor Program and the Standardized Plant Analysis Risk Models," Washington, D.C. USA (<http://www.nrc.gov/reading-rm/doc-collections/commission/secys/2010/secy2010-0125/2010-0125scy.pdf>).

U.S. NRC, March 5, 2011, Letter from Toshiba to NRC having Subject: Toshiba Corporation (Toshiba) Response for the 4S Reactor (4S) to Regulatory Issue Summary (RIS) 2011-02, Washington, D.C. (<http://www.nrc.gov/docs/ML1108/ML110820191.pdf>).

Waste Management Symposia, Inc., March 2000, "Status of the AVR Decommissioning Project with Special Regard to the Inspection of the Core Cavity for Residual Fuel," Waste Management '00 Conference, February 27 - March 2000, Tucson, AZ (<http://www.wmsym.org/archives/2000/pdf/36/36-5.pdf>).

Waste Management Symposia, Inc., February 2013, "Exploratory Design of a Reactor/Fuel Cycle Using Spent Nuclear Fuel Without Conventional Reprocessing - 13579," Waste Management 2013 Conference, February 24 - 28, Tucson, AZ (<http://www.wmsym.org/archives/2013/papers/13579.pdf>).

Westinghouse, 2013, "Nuclear Power - A Journey of Continuous Improvement" ([https://engineering.tamu.edu/media/948603/bowser\\_ppt.pdf](https://engineering.tamu.edu/media/948603/bowser_ppt.pdf)).

Westinghouse Electric Company, January 2014, letter to USNRC Document Control Desk, Subject: "Response to NRC Regulatory Issue Summary 2013-18, 'Licensing Submittal Information and Design Development Activities for Small Modular Reactor Designs,'" January 31, 2014, ADAMS Accession Number ML14041A015 (<https://adamswebsearch2.nrc.gov/webSearch2/main.jsp?AccessionNumber=ML14041A015>).



Westinghouse Electric Company, 2015, "Westinghouse Advances SMR Design Certificate with US NRC Approval of Safety Testing Program," March 17, 2015 ([http://www.westinghousenuclear.com/About/News/View/articleid/584?dnnprintmode=true&mid=1049&SkinSrc=%5BG%5DSkins%2F\\_default%2FNo+Skin&ContainerSrc=%5BG%5DContainers%2F\\_default%2FNo+Container](http://www.westinghousenuclear.com/About/News/View/articleid/584?dnnprintmode=true&mid=1049&SkinSrc=%5BG%5DSkins%2F_default%2FNo+Skin&ContainerSrc=%5BG%5DContainers%2F_default%2FNo+Container)).

World Nuclear Association (WNA), June 2016, "Small Nuclear Power Reactors," London, United Kingdom (<http://www.world-nuclear.org/information-library/nuclear-fuel-cycle/nuclear-power-reactors/small-nuclear-power-reactors.aspx>).

World Nuclear News (WNN), 10 February 2014, "Construction of CAREM underway," London, England (<http://www.world-nuclear-news.org/NN-Construction-of-CAREM-underway-1002144.html>).

WNN, September 14, 2016, "Terrestrial Energy to complete US loan guarantee application," London, England (<http://www.world-nuclear-news.org/NN-Terrestrial-Energy-to-complete-US-loan-guarantee-application-1409167.html>).

X-energy, September 2014, "Xenergy," NRC-DOE Workshop on Advanced Non-LWRs, September 1, 2015, Rockville, MD, USA (<http://www.nrc.gov/docs/ML1524/ML15247A020.pdf>).

X-energy, October 2015, "The Xe-100 - A Different Kind of Nuclear Reactor," October 27, 2015 ([http://2262-presscdn-27-11.pagely.netdna-cdn.com/wp-content/uploads/ANS\\_X-energy-Presentation\\_PUBLIC\\_10-28-15.pdf](http://2262-presscdn-27-11.pagely.netdna-cdn.com/wp-content/uploads/ANS_X-energy-Presentation_PUBLIC_10-28-15.pdf)).



## **Appendix A**

### **Comprehensive WANT Statement**



# Appendix A

## Comprehensive WANT Statement

- **Defining** the area to be explored
  - Small Modular Nuclear Reactors (SMNRs) are small scale (typically 5 – 300 MWe) nuclear energy (nuclear fission) power plants capable of producing electricity, heat and desalinated water for a broad range of applications.
  - An SMNR Technology Intelligence study is to be carried out to provide insight for the following points of consideration:
    - a) In the last 5 years (i.e. since 2011) what have been the salient changes and trends in the development of SMNR technologies?
    - b) With regards to safety, what has been the operational experience with SMNRs in existing applications i.e. power plants (China, India, Pakistan and Siberia have operating SMNRs) submarines and ships?
    - c) In relation to b) above, in the event of a safety breach/hazardous event, what were the causal factors and how has the technology evolved to address them?
    - d) Considering three applications in Alberta: (I) Combined Heat and Power Supply for a Steam Assisted Gravity Drainage (SAGD) Operation (II) Power Generation in Alberta's Electricity Market (III) Generation of Power, Heat and Desalinated Water in Alberta's Remote Communities - what are the characteristics of current and emerging SMNR technologies in relation to the following:

### 1) **Non-Technical Factors:**

- Licensing and regulatory challenges: From and Alberta perspective, what are the impediments to the deployment of the technology in this area? How can these impediments be overcome?
- Public perception: Is the public perception of the technology different from large scale nuclear power plants (NPP)? If not, how can the perception be differentiated?
- Estimated time to commercialization: When will emerging SMNR technologies, be ready for commercial scale deployment? Are there emerging SMNR technologies that will be commercially deployable by 2030?

- Expertise required for operation: What is the degree of expertise required for SMNR plant operation?
- Security risks: What is the nature of the proliferation risk associated with SMNRs? How can these risks be managed?

## 2) Technical Factors:

- Technology readiness level: Using AI definitions, of the emerging SMNR technologies, which technologies are at TRL – 5 or greater?
- SAGD: Steam generation quality: Is the existing/emerging SMNR steam quality suitable for a SAGD operation of 30,000 bpd requiring a steam pressure and temperature of 9 MPa and 315°C (assuming a steam to oil ratio range of 2 to 3), respectively, and an electricity generation capacity of 11 – 18 MWe? Otherwise, are the existing/emerging SMNR technologies only suitable for Alberta’s electricity market, remote communities, or both?
- Electricity Market and Remote Communities: Power, Heat and Desalinated Water Specification: For deployment in Alberta’s electricity market and remote communities, the desired power capacity ranges from 5 MW – 300 MW. The required heat generation capacity is 11,500 MWh(th)/yr for remote communities, with a desalinated water production of 100,000 m<sup>3</sup>/yr.
- Baseload and non-baseload operability: For application in Alberta’s electricity market, does the technology have flexibility in its mode of operation? Is it operable at baseload or non-baseload conditions without introduction of technical issues?
- Inherent/passive safety design features: What safety features are inherent in the technology design of existing/emerging SMNRs? What is the degree of human intervention required to activate the safety features?
- Fuel type, quantity and fuel enrichment required: What fuel is used in the technology? How much does it cost? What is the quantity of fuel consumed per unit of electrical and heat energy produced i.e. kg of fuel per MWh(e) or MWh(th)? What is the frequency of refueling? What is the degree of fuel enrichment required?
- Decommissioning Requirements: What are the requirements in terms of tools/infrastructure, to decommission an SMNR plant and are they different from a NPP?

### 3) Environmental Factors:

- Waste generation and waste handling: How much radioactive waste is produced from the SMNR technology? What are the handling requirements for the radioactive waste? Are there any other wastes produced by the technology? How will they be handled?
- Operability in Alberta's climate: Can the SMNR technology operate successfully in Alberta's climate, considering a temperature range of -50°C to 40°C?

### 4) Economic Factors:

- Capital cost: What is the capital cost of the technology in (\$/kW)?
- Operating and maintenance cost: What is the operating and maintenance cost in \$/kWh(e) and \$/kWh(th)?
- Levelized cost of electricity: What is the levelized cost of electricity in \$/kWh(e) at a discount rate of 10%?
- Levelized cost of heat production: What is the levelized cost of heat production in \$/kWh(th) at a discount rate of 10%?

#### ○ Key Intelligence Outcomes:

- Which SMNR existing/emerging technologies satisfy the operational requirements of SAGD, Electricity Markets or Remote Communities applications?
- Can the aforementioned technical and non-technical factors which pose challenges to SMNR technologies, be overcome?
- What will be the innovative solutions to overcome these challenges?

#### ○ Identifying *emerging* technologies and management systems

- Emerging SMNR technologies that are at pre-commercial or commercial stages of development

#### ○ Assessing potential changes in Alberta and Federal regulations – as known from public sources at this time.

- Alberta's climate leadership plan mandated the complete phase-out of coal powered plants by 2030.
- A cap on oil sands industry emissions of 100 MT/yr to come into force.
- An economy-wide carbon tax of \$30/ton CO<sub>2e</sub> to be implemented by 2018.

- **Purpose of the work:**
  - Providing technology intelligence to AI in the area of SMNR technologies and their deployability for Alberta applications.
  - Identifying economic diversification, environmental and social development opportunities and benefits for Alberta.

<b>Scientific soundness</b>	Technologies should be scientifically sound and validated at TRL 5 (see AI TRL definitions below) or better.
<b>General fit with AI's mandate</b>	This project fits AI's 2030 goals: <ul style="list-style-type: none"> <li>• 50% intensity reduction in Alberta's GHG emissions.</li> </ul>
<b>Duplication</b>	Some previous work has been conducted by Petroleum Technology Alliance Canada (PTAC), where the use of NPPs as well as high temperature gas cooled SMNRs for SAGD and surface mining applications in Alberta's oil sands industry, was investigated. The PTAC studies and another report produced by MIT (2007), focus on oil sands applications and are representative of the state of the technology as of 2011 in the best case. Technology intelligence studies which investigate SMNR deployment in Alberta's electricity market and remote communities, along with oil sands (SAGD) applications are relatively scarce. Moreover, some notable developments in the SMNR technology landscape are likely to have occurred since 2011.
<b>Technical feasibility/likely high technology readiness level</b>	Technical feasibility is high, with some existing small commercial nuclear plants already deployed around the globe. SMNR technologies at TRL 5 or greater are desired in this study.
<b>Commercialization Potential</b>	Commercialization potential is significant – there are some small nuclear reactor plants (e.g. China, India, Pakistan and Siberia) in operation; however, the operational experience of these plants is unknown to AI at this time.
<b>Benefits for Alberta</b>	<ul style="list-style-type: none"> <li>• Economic diversification – including the potential use of Alberta's uranium resources. Neighboring Saskatchewan is also the world's second largest producer of uranium – presenting strong supply chain benefits.</li> <li>• GHG mitigation.</li> <li>• Development of remote communities</li> <li>• Carbon neutral value added products</li> </ul>



<b>TRL</b>	<b>AIEES - Standard definition/classification</b>
1	Basic principles observed and reported
2	Technology concept and/or application formulated
3	Analytical and experimental critical function and/or characteristic proof-of-concept
4	Component/subsystem validation in laboratory environment
5	Component validation in relevant environment
6	System/subsystem model or prototyping demonstration in a simulated end-to-end environment; typically 0.1 to 5% of full scale
7	System prototyping demonstration in an operational environment; typically Pilot Plant at 5% of Full Scale
8	Actual system completed and qualified through test and demonstration in an operational environment; demonstration at typically 25% of commercial scale
9	Actual system proven through successful deployment in an operational setting; commercial operation
10	Widespread Adoption



## **Appendix B**

### **Assigned Scores for Each Ranking Model**



## **Appendix B**

### **Assigned Scores for Each Ranking Model**

This appendix provides the scores assigned for each of the criteria to each of the SMNR concepts evaluated in this report. Table B-1 provides the assigned scores for the “Full Compliance Ranking Model.” Table B-2 provides the assigned scores for the “Full and Partial Compliance Ranking Model.”

Table B-1. Scores for the Full Compliance Ranking Model

Technology	SAGD - APPLICATION CRITERIA												
	Commercial Deployment	Steam Quality	TRL	Steam Production	Power Rating	Safety		Spent Fuel Management		LLW/ILW Management	Decommissioning	Alberta Adaptability	LCOE
Small Modular Nuclear Reactors	Deployable by 2030	P&T ≥ 9MPa & 315°C	TRL ≥ 5	Capable of yielding ≥ 655,220 kg/hr	11MW ≤ PR ≤ 18MW	Inherent/Passive Safety Features to Prevent/Mitigate Severe Accidents	Does not use coolant that is chemically-reactive with air or water	Spent fuel does not require treatment after discharge	Reactor vendor dispositions the used nuclear fuel	Plant generates little or no ILW/LLW during operation	Decommissioning has been demonstrated	No nuclear trained operators required	LCOE is competitive with combined-cycle natural gas
<b>Maximum Compliance:</b>	<b>YES</b>	<b>YES</b>	<b>YES</b>	<b>YES</b>	<b>YES</b>	<b>YES</b>	<b>YES</b>	<b>YES</b>	<b>YES</b>	<b>YES</b>	<b>YES</b>	<b>YES</b>	<b>YES</b>
ACP100	YES	NO	YES	YES	NO	YES	YES	YES	NO	NO	YES	NO	NO
mPower	YES	NO	YES	YES	NO	YES	YES	YES	NO	NO	YES	NO	NO
CAREM-25	YES	NO	YES	YES	NO	YES	YES	YES	NO	NO	YES	NO	NO
FBNR	NO	NO	NO	YES	NO	YES	YES	YES	NO	NO	NO	NO	NO
SMR-160	YES	NO	NO	YES	NO	YES	YES	YES	NO	NO	YES	NO	NO
NuScale	YES	NO	YES	YES	NO	YES	YES	YES	NO	NO	YES	NO	NO
SMART	YES	NO	YES	YES	NO	YES	YES	YES	NO	NO	YES	NO	NO
Westinghouse SMR	YES	NO	YES	YES	NO	YES	YES	YES	NO	NO	YES	NO	NO
AHWR300-LEU	YES	NO	NO	YES	NO	YES	YES	YES	NO	NO	NO	NO	NO
PHWR-220	YES	NO	YES	YES	NO	NO	YES	YES	NO	NO	NO	NO	NO
GT-HTR300	NO	YES	YES	YES	NO	YES	YES	YES	NO	NO	YES	NO	NO
GT-MHR	NO	YES	YES	YES	NO	YES	YES	YES	NO	NO	YES	NO	NO
HTR50S	YES	YES	YES	YES	YES	YES	YES	YES	NO	NO	YES	NO	NO
HTR-PM	YES	YES	YES	YES	NO	YES	YES	YES	NO	NO	YES	NO	NO
SC-HTGR	YES	YES	YES	YES	NO	YES	YES	YES	NO	NO	YES	NO	NO
StarCore	NO	YES	NO	YES	YES	YES	YES	YES	YES	YES	YES	YES	NO
Xe-100	YES	YES	YES	YES	NO	YES	YES	YES	NO	NO	YES	NO	NO
IMSR	NO	YES	NO	YES	NO	YES	YES	NO	NO	NO	NO	NO	NO
TMSR-SF	NO	YES	NO	YES	NO	YES	YES	YES	NO	NO	NO	NO	NO
TMSR-LF	NO	YES	NO	YES	NO	YES	YES	NO	NO	NO	NO	NO	NO
4S	YES	YES	YES	YES	YES	YES	NO	YES	NO	NO	NO	NO	NO
PGSFR	NO	YES	NO	YES	NO	YES	NO	YES	NO	NO	NO	NO	NO
PRISM	YES	YES	YES	YES	NO	YES	NO	YES	NO	NO	NO	NO	NO
EM <sup>2</sup>	NO	YES	NO	YES	NO	YES	YES	YES	NO	NO	YES	NO	NO
G4M	NO	NO	NO	YES	NO	YES	YES	YES	YES	YES	NO	NO	NO
SVBR-100	NO	NO	NO	YES	NO	YES	YES	YES	NO	NO	NO	NO	NO

B.2

Table B-2. Scores for the Full and Partial Compliance Ranking Model

Technology	SAGD - APPLICATION CRITERIA												
	Commercial Deployment	Steam Quality	TRL	Steam Production	Power Rating	Safety		Spent Fuel Management		LLW/ILW Management	Decommissioning	Alberta Adaptability	LCOE
Small Modular Nuclear Reactors	Deployable by 2030	P&T ≥ 9MPa & 315°C	TRL ≥5	Capable of yielding ≥ 655,220 kg/hr	11MW ≤ PR ≤ 18MW	Inherent/Passive Safety Features to Prevent/Mitigate Severe Accidents	Does not use coolant that is chemically-reactive with air or water	Spent fuel does not require treatment after discharge	Reactor vendor dispositions the used nuclear fuel	Plant generates little or no ILW/LLW during operation	Decommissioning has been demonstrated	No nuclear trained operators required	LCOE is competitive with combined-cycle natural gas
<b>Maximum Score:</b>	<b>10</b>	<b>10</b>	<b>10</b>	<b>10</b>	<b>10</b>	<b>10</b>	<b>10</b>	<b>10</b>	<b>10</b>	<b>10</b>	<b>10</b>	<b>10</b>	<b>10</b>
ACP100	7	1	10	4	4	4	10	4	3	5	7	6	4
mPower	6	1	10	6	1	4	10	6	3	5	7	7	4
CAREM-25	8	1	10	4	8	2	10	2	2	5	7	5	4
FBNR	1	1	1	2*	4	8	10	10	10	8	10	6	4
SMR-160	3	1	4	2	1	10	10	6	3	5	7	7	4
NuScale	6	1	10	4	6	10	10	4	3	5	7	6	5
SMART	6	1	10	6	4	2	10	4.5	4	5	7	7	4
Westinghouse SMR	4	1	8	2*	1	6	10	4	4	5	7	6	4
AHWR300-LEU	6	1	6	8	1	6	10	1	4	5	4	2	4
PHWR-220	9	1	10	4	1	1	10	1	1	5	4	2	3
GT-HTR300	5	10	10	10	1	8	10	4	6	8	4	6	6
GT-MHR	3	10	10	10	1	8	10	4	6	8	4	6	5
HTR50S	3	10	10	10	10	8	10	4	4	8	4	6	6
HTR-PM	8	10	10	10	1	8	10	1	4	8	4	2	6
SC-HTGR	3	10	10	10	1	8	10	4	6	8	4	6	5
StarCore	1	10	1	10	10	8	10	10	10	10	10	10	6
Xe-100	2	10	8	10	6	8	10	1	4	8	4	2	5
IMSR	2	10	6	10	6	6	10	8	8	5	1	8	6
TMSR-SF	1	10	6	10	6	6	10	1	6	8	4	2	5
TMSR-LF	1	10	4	10	6	6	10	4	8	5	1	1	4
4S	7	10	10	10	10	8	1	9	3	10	4	9	3
PGSFR	2	10	8	10	1	5	1	2	4	6	4	5	3
PRISM	6	10	10	10	1	8	1	4	6	6	4	6	3
EM <sup>2</sup>	3	10	6	10	1	8	10	9	6	8	4	8	5
G4M	3	1	4	1	8	7	10	10	10	8	10	9	5
SVBR-100	3	1	6	6	4	4	10	8	6	5	1	7	5

\*A value of 2 assumed, the same as the lowest value of all iPWRs (i.e., SMR-160) because the information is not available (NA)

B.3









**Pacific Northwest**  
NATIONAL LABORATORY

*Proudly Operated by **Battelle** Since 1965*

902 Battelle Boulevard  
P.O. Box 999  
Richland, WA 99352  
1-888-375-PNNL (7665)

U.S. DEPARTMENT OF  
**ENERGY**

---

[www.pnnl.gov](http://www.pnnl.gov)